

**LEIF MEJLBRO**

**REAL FUNCTIONS IN ONE VARIABLE -  
SIMPLE 1...**

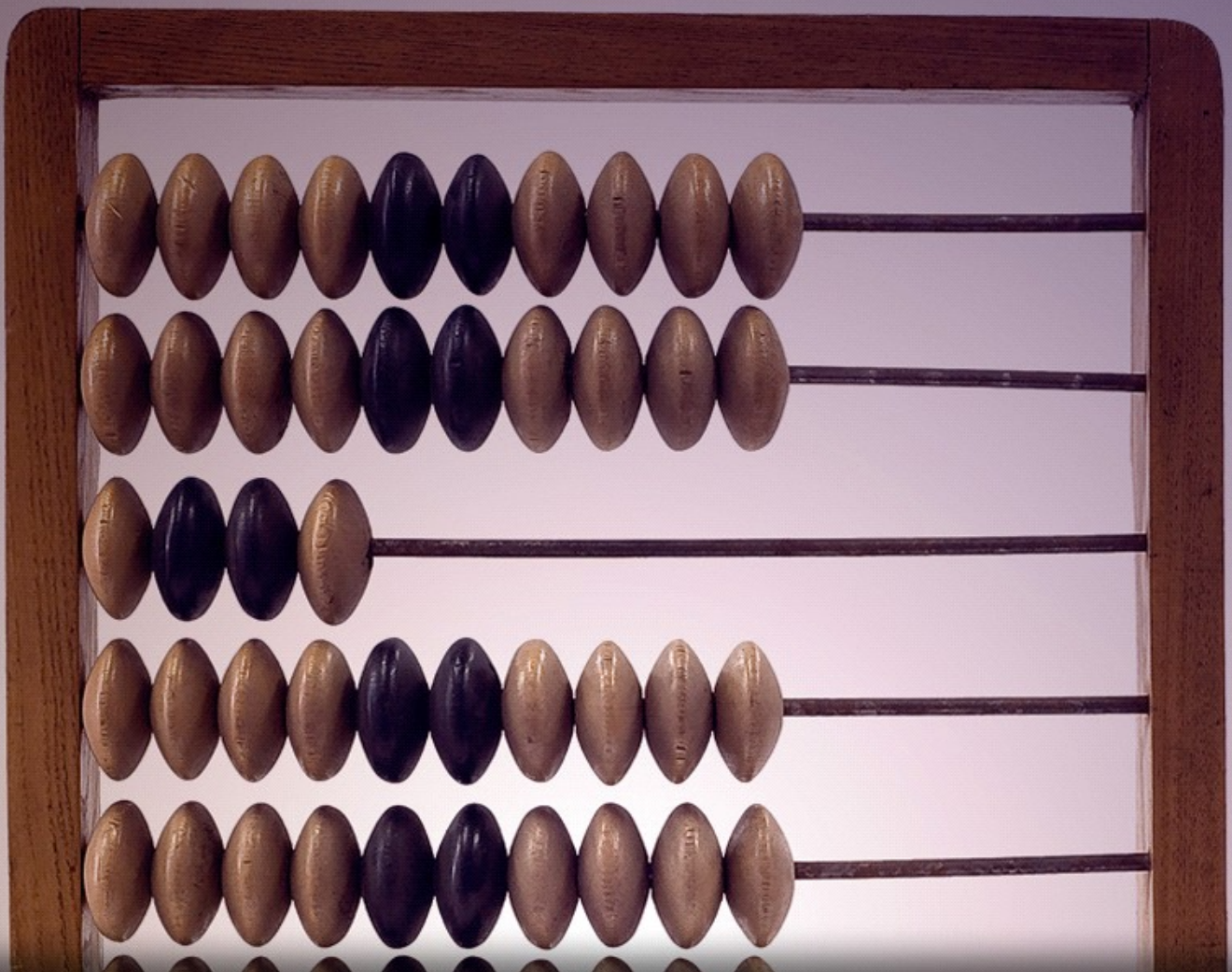

DOWNLOAD FREE TEXTBOOKS AT  
**BOOKBOON.COM**

Leif Meilbro

---

Real Functions in One Variable

Simple Differential Equations I

Calculus 1c-1

---

---

Real Functions in One Variables – Simple Differential Equations I – Calculus 1c-1  
© 2007 Leif Mejlbro & Ventus Publishing ApS  
ISBN 978-87-7681-236-2

# Contents

<b>Preface</b>	<b>5</b>
<b>1. Some theorems constantly applied in the following</b>	<b>6</b>
<b>2. Separation of the variables</b>	<b>7</b>
<b>3. Linear differential equation of first order</b>	<b>39</b>
<b>4. The Existence and Uniqueness Theorem and other theoretical considerations</b>	<b>69</b>
<b>5. The Bernoulli differential equation</b>	<b>79</b>
<b>6. The setup of model equations</b>	<b>91</b>
<b>7. MAPLE programmes</b>	<b>117</b>

Please click the advert

## WHAT'S MISSING IN THIS EQUATION?

You could be one of our future talents

### MAERSK INTERNATIONAL TECHNOLOGY & SCIENCE PROGRAMME

Are you about to graduate as an **engineer** or **geoscientist**? Or have you already graduated?  
If so, there may be an exciting future for you with A.P. Moller - Maersk.



**MAERSK**

[www.maersk.com/mitas](http://www.maersk.com/mitas)

## Preface

In this volume I present some examples of *Simple Differential Equations I*, cf. also *Calculus 1a, Functions of One Variable*. Since my aim also has been to demonstrate some solution strategy I have as far as possible structured the examples according to the following form

**A** *Awareness*, i.e. a short description of what is the problem.

**D** *Decision*, i.e. a reflection over what should be done with the problem.

**I** *Implementation*, i.e. where all the calculations are made.

**C** *Control*, i.e. a test of the result.

This is an ideal form of a general procedure of solution. It can be used in any situation and it is not linked to Mathematics alone. I learned it many years ago in the Theory of Telecommunication in a situation which did not contain Mathematics at all. The student is recommended to use it also in other disciplines.

One is used to from high school immediately to proceed to **I. Implementation**. However, examples and problems at university level are often so complicated that it in general will be a good investment also to spend some time on the first two points above in order to be absolutely certain of what to do in a particular case. Note that the first three points, **ADI**, can always be performed.

This is unfortunately not the case with **C Control**, because it from now on may be difficult, if possible, to check one's solution. It is only an extra securing whenever it is possible, but we cannot include it always in our solution form above.

I shall on purpose not use the logical signs. These should in general be avoided in Calculus as a shorthand, because they are often (too often, I would say) misused. Instead of  $\wedge$  I shall either write "and", or a comma, and instead of  $\vee$  I shall write "or". The arrows  $\Rightarrow$  and  $\Leftrightarrow$  are in particular misunderstood by the students, so they should be totally avoided. Instead, write in a plain language what you mean or want to do.

It is my hope that these examples, of which many are treated in more ways to show that the solutions procedures are not unique, may be of some inspiration for the students who have just started their studies at the universities.

Finally, even if I have tried to write as careful as possible, I doubt that all errors have been removed. I hope that the reader will forgive me the unavoidable errors.

Leif Mejlbro  
17th July 2007

## 1 Some theorems constantly applied in the following

**Theorem 1.1** Solution by separation. Consider a differential equation of the form

$$(1) \quad \frac{dx}{dt} = f(t)g(x), \quad (t, x) \in I_1 \times I_2,$$

where  $f : I_1 \rightarrow \mathbb{R}$  and  $g : I_2 \rightarrow \mathbb{R}$  are both continuous functions, and where  $g(x) \neq 0$  for every  $x \in I_2$ . The complete solution of (1) is given by

$$\int \frac{dx}{g(x)} = \int f(t) dt + c,$$

where  $c \in \mathbb{R}$  is some arbitrary constant.

Informally we write (1) in the following form (divide by  $g(x) \neq 0$  and “multiply” by  $dt$ )

$$\frac{dx}{g(x)} = f(t) dt.$$

Here,  $x$  and  $dx$  only occur on the left hand side, while  $t$  and  $dt$  only occur on the right hand side. For that reason we say that the *variables can be separated*.

**Theorem 1.2** Solution of a linear differential equation of first order. Consider an equation of the form

$$(2) \quad \frac{dx}{dt} + p(t)x = q(t), \quad t \in I,$$

where the functions  $p(t)$  and  $q(t)$  are both continuous in the interval  $I$ .

The complete solution of the differential equation (2) is given by

$$(3) \quad x(t) = e^{-P(t)} \left\{ \int e^{P(t)} q(t) dt + c \right\}, \quad t \in I, \text{ and where } c \in \mathbb{R} \text{ are arbitrary}$$

Here we have put

$$P(t) = \int p(t) dt.$$

When  $q(t) = 0$  in (2), the differential equation is called *homogeneous*. When  $q(t) \neq 0$  in (2), the differential equation is called *inhomogeneous*. Homogeneous equations are usually easier to solve than inhomogeneous ones. Therefore, one often starts by first solving the homogeneous equation, e.g. by (3),

$$x(t) = c \cdot e^{-P(t)}, \quad t \in I, \quad c \in \mathbb{R} \text{ arbitrary,}$$

where as before  $P(t) = \int p(t) dt$ .

The following theorem follows from the linearity:

**Theorem 1.3** The complete solution of (2) is obtained by adding all the solutions of the corresponding homogeneous equation to any solution of the inhomogeneous equation.

## 2 Separation of the variables

**Example 2.1** Find the solution  $x = f(t)$  of the differential equation

$$\frac{dx}{dt} = \frac{5t}{x}, \quad x > 0, \quad t \in \mathbb{R},$$

for which  $f(0) = 1$ .

**A.** The equation is a first order differential equation, in which the variables can be separated:

$$\frac{dx}{dt} = \varphi(t) \psi(x), \quad x > 0, \quad t \in \mathbb{R},$$

where

$$\varphi(t) = 5t \quad \text{and} \quad \psi(x) = \frac{1}{x},$$

and where the initial value is  $f(0) = 1$ .

**D.** The equation is solved by separation of the variables, e.g. by an application of theorem 1.1. I shall here give two variants of solution. They both start by determining the complete solution.

**I. First solution.** Here we apply theorem 1.1.

Since  $\psi(x) = \frac{1}{x} \neq 0$  for every  $x > 0$ , we get

$$\begin{cases} G(x) = \int \frac{1}{\psi(x)} dx = \int x dx = \frac{x^2}{2}, \\ F(t) = \int \varphi(t) dt = \int 5t dt = \frac{5}{2} t^2. \end{cases}$$

The complete solution is given by

$$\frac{x^2}{2} = \frac{5}{2}t^2 + c, \quad x > 0, \quad c \in \mathbb{R}, \quad t \in I_c,$$

where the condition  $x > 0$  implies that every  $t \in I_c$  must satisfy

$$\frac{5}{2}t^2 + c > 0.$$

Hence, the solutions can also be written in the form

$$x^2 = 5t^2 + 2c, \quad x > 0, \quad c \in \mathbb{R}, \quad t \in I_c,$$

where  $c \in \mathbb{R}$  is an arbitrary constant, and  $I_c$  is the corresponding domain.

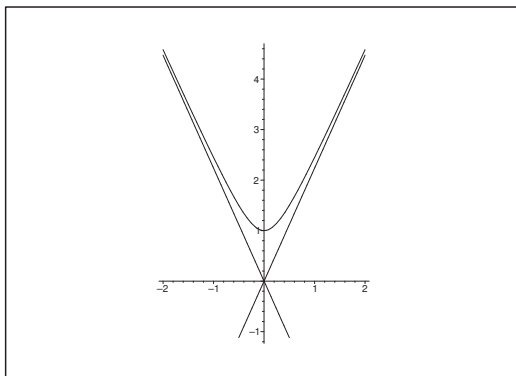

Figure 1: The solution for which  $f(0) = 1$ , including its asymptotes.

For  $t = 0$  we get  $x = 1$ , i.e.  $c = \frac{1}{2}$ , and this particular solution is given by

$$x^2 = 5t^2 + 1, \quad x > 0, \quad t \in \mathbb{R}.$$

When we rewrite this as

$$x^2 - (\sqrt{5}t)^2 = 1, \quad x > 0, \quad t \in \mathbb{R},$$

we see that its graph is an hyperbolic branch in the upper half plan with the asymptotes  $x = \pm\sqrt{5}t$ . The solution is also written

$$x = f(t) = \sqrt{5t^2 + 1}, \quad t \in \mathbb{R},$$

where we exploit that  $x > 0$ .

**Second solution.** A small rearrangement of the equation. When we multiply the equation by  $2x$ , we get by the rules of calculation that

$$2x \frac{dx}{dt} = \frac{d(x^2)}{dt} = 10t, \quad x > 0, \quad t \in \mathbb{R},$$



hence by an integration,

$$x^2 = 5t^2 + c, \quad x > 0, \quad c \in \mathbb{R}, \quad t \in I_c,$$

where  $c \in \mathbb{R}$  is an arbitrary constant, and where every  $t \in I_c$  satisfies the condition  $5t^2 + c > 0$ .

For the particular solution we get  $c = 1$ , when  $t = 0$ . Thus we get  $x^2 = 5t^2 + 1$  under the constraint that  $x > 0$ , i.e. an hyperbolic branch in the upper half plane, cf. the figure. Since  $x > 0$ , we also have

$$x = f(t) = \sqrt{5t^2 + 1}, \quad t \in \mathbb{R}.$$

**C. TEST:** When  $x = f(t) = \sqrt{5t^2 + 1}$ ,  $t \in \mathbb{R}$ , it is obvious that

$$f(0) = \sqrt{5 \cdot 0^2 + 1} = 1,$$

so the initial condition is satisfied.

Furthermore

$$\frac{dx}{dt} = \frac{1}{2} \cdot \frac{1}{\sqrt{5t^2 + 1}} \cdot 5 \cdot 2t = \frac{5t}{x},$$

and we have checked the solution.

Finally,  $x = f(t) \geq 1 > 0$  for every  $t \in \mathbb{R}$ , and we have proved all conditions in the example.

**Example 2.2** . Find the solution  $x = f(t)$  of the differential equation

$$\frac{dx}{dt} = 4t\sqrt{x}, \quad x > 0, \quad t \in \mathbb{R},$$

for which  $f(2) = 1$ . Find in particular the domain of the solution.

**A.** The equation is a first order differential equation in which the variables can be separated:

$$\frac{dx}{dt} = \varphi(t)\psi(x), \quad x > 0, \quad t \in \mathbb{R},$$

where

$$\varphi(t) = 2t \quad \text{and} \quad \psi(x) = 2\sqrt{x},$$

and where the initial condition is  $f(2) = 1$ .

**D.** The equation can either be solved by the method of separation of the variables, e.g. by applying theorem 1.1, or by a small trick. The constant follows from the initial condition. Finally, discuss the domain.

**I. First solution.** *Application of theorem 1.1.*

Since  $\psi(x) = 2\sqrt{x} \neq 0$  for every  $x > 0$ , we get

$$\begin{cases} G(x) = \int \frac{1}{\psi(x)} dx = \int \frac{1}{2\sqrt{x}} dx = \sqrt{x}, \\ F(t) = \int \varphi(t) dt = \int 2t dt = t^2. \end{cases}$$

The complete solution is then

$$\sqrt{x} = t^2 + c, \quad t \in I_c,$$

where  $t \in I_c$  must satisfy  $t^2 + c > 0$ .

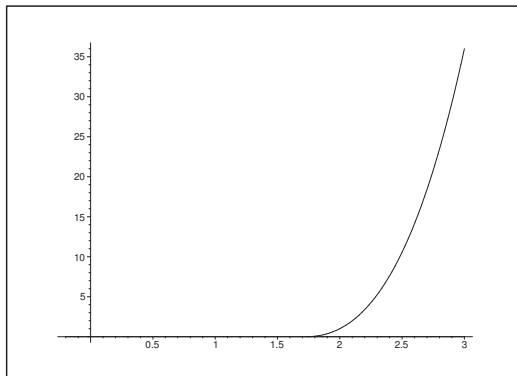

Figure 2: The solution  $f(t) = (t^2 - 3)^2$  for  $t > \sqrt{3}$ .

When  $(t, x) = (2, 1)$ , we get  $c = \sqrt{1} - 2^2 = -3$ , hence the searched solution is given by

$$\sqrt{x} = t^2 - 3, \quad t \in I_c,$$

where the domain  $I_c$  is described by  $t^2 > 3$  and  $2 \in I_c$ , i.e.

$$I_c = ]\sqrt{3}, +\infty[.$$

Notice that the other possible interval,  $] -\infty, -\sqrt{3}[$ , actually does not give the correct solution.

We now obtain our solution by squaring,

$$x = (t^2 - 3)^2, \quad t \in ]\sqrt{3}, +\infty[.$$

**Second solution.** “The divine inspiration”. (It is not so “divine” as one might think, when one just has tried this method a couple of times).

When the equation is divided by  $2\sqrt{x} > 0$ , we get

$$\frac{1}{2\sqrt{x}} \frac{dx}{dt} = \frac{d(\sqrt{x})}{dt} = 2t,$$

from which by an integration

$$\sqrt{x} = t^2 + c, \quad t \in I_c,$$

where the interval  $I_c$  is determined by  $t^2 + c > 0$  (because  $x > 0$ ) and  $2 \in I_c$ . The rest is done like in the **First solution**.

C. Now let

$$x = (t^2 - 3)^2 \quad \text{for } t \in ]\sqrt{3}, +\infty[.$$

Then we get in this interval that

$$\sqrt{x} = |t^2 - 3| = t^2 - 3 > 0.$$

When  $t = 2 \in ]\sqrt{3}, +\infty[$  we get

$$x = f(2) = (4 - 3)^2 = 1.$$

Finally, by insertion in the differential equation,

$$\frac{dx}{dt} = 2(t^2 - 3) \cdot 2t = 4t\sqrt{x}, \quad x > 0,$$

and the solution has been checked.

Please click the advert

# CHALLENGE YOURSELF

## WWW.STUDYINSWEDEN.SE

**Si.**  
Swedish Institute

Today's job market values ambitious, innovative, perceptive team players. Swedish universities foster these qualities through a forward-thinking culture where you're close to the latest ideas and global trends.

Whatever your career goals may be, studying in Sweden will give you valuable skills and a competitive advantage for your future. [www.studyinsweden.se](http://www.studyinsweden.se)

**Example 2.3** . Find the complete solution of the differential equation

$$\frac{dx}{dt} = 4t\sqrt{x}, \quad x > 0, \quad t \in \mathbb{R}.$$

Indicate in particular those functions which are solutions for every  $t \in \mathbb{R}$ . Draw in a  $(t, x)$  coordinate system the solution curves which go through the following points:

$$(1) (t, x) = (0, 1), \quad (2) (t, x) = (1, 1), \quad (3) (t, x) = (\sqrt{2}, 1).$$

**A.** The differential equation is the same as the differential equation in Example 2.2, so we can reuse the former solution. Here we shall discuss the domain.

**D.** Either retrieve the complete solution of Example 2.2, or repeat one of the variants from **I.** in Example 2.2. Then find the constants  $c \in \mathbb{R}$ , for which  $I_c = \mathbb{R}$ .

**I.** We choose of course here to reuse the complete solution from Example 2.2, i.e.

$$\sqrt{x} = t^2 + c, \quad t \in I_c, \quad x > 0,$$

where  $I_c$  is a connected subset of the set of points  $t$ , for which  $t^2 + c > 0$ . Therefore, if  $I_c = \mathbb{R}$ , we must have  $t^2 + c > 0$  for every  $t \in \mathbb{R}$ , i.e.  $c > 0$ .

When this is the case, we get

$$x = (t^2 + c)^2, \quad t \in \mathbb{R}, \quad c > 0.$$

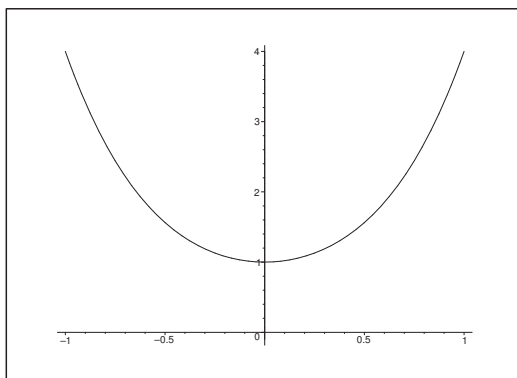

Figure 3: The solution  $x = (t^2 + 1)^2$ .

1) When the point  $(t, x) = (0, 1)$  lies of the solution curve, then

$$\sqrt{x} = \sqrt{1} = 1 = t^2 + c = 0^2 + c = c,$$

i.e.  $c = 1$ , and the searched for solution is

$$x = (t^2 + 1)^2, \quad t \in \mathbb{R}.$$

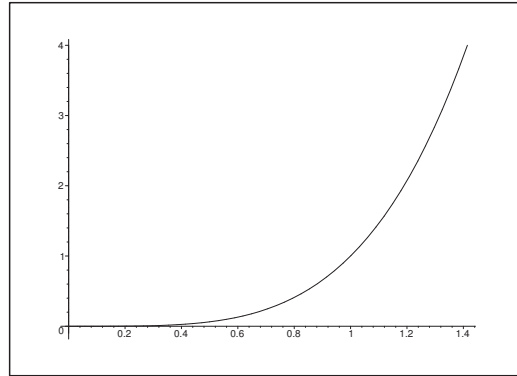
Figure 4: The solution  $x = t^4$  for  $t > 0$ .

2) When the point  $(t, x) = (1, 1)$  lies on the solution curve, then

$$\sqrt{x} = \sqrt{1} = 1 = t^2 + c = 1^2 + c = 1 + c,$$

i.e.  $c = 0$ , and  $\sqrt{x} = t^2$ . Then note that  $t^2 > 0$  for  $t > 0$  or  $t < 0$ . Since we shall choose that interval, in which  $t = 1$  is situated, the solution must be

$$x = t^4, \quad \text{for } t > 0.$$

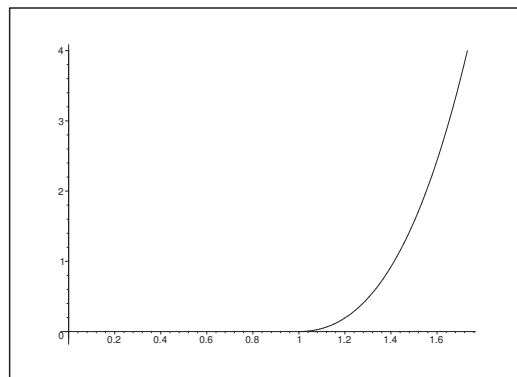
Figure 5: The solution  $x = (t^2 - 1)^2$  for  $t > 1$ .

3) When the point  $(t, x) = (\sqrt{2}, 1)$  lies on the solution curve, we must have

$$\sqrt{x} = \sqrt{1} = 1 = t^2 + c = (\sqrt{2})^2 + c = 2 + c,$$

i.e.  $c = -1$ , and  $\sqrt{x} = t^2 - 1 > 1$  for either  $t > 1$  or  $t < -1$ . Since  $t = \sqrt{2}$  must belong to the interval  $I_{-1}$ , the solution is given by

$$x = (t^2 - 1)^2, \quad \text{for } t > 1.$$

**Example 2.4** . Find the solution  $x = f(t)$  of the differential equation

$$\frac{dx}{dt} = x^{\frac{2}{3}} \sin t, \quad t \in \mathbb{R}, \quad x \in \mathbb{R},$$

for which  $f(0) = 1$ .

**A.** The equation is a first order differential equation, in which the variables can be separated,

$$\frac{dx}{dt} = \varphi(t) \psi(x), \quad t \in \mathbb{R}, \quad x \in \mathbb{R},$$

where

$$\varphi(t) = \sin t \quad \text{and} \quad \psi(x) = x^{\frac{2}{3}},$$

and where the initial condition is  $f(0) = 1$ .

Now,  $\psi(x) = x^{\frac{2}{3}}$  is 0 for  $x = 0$ , so we must assume that  $x \neq 0$ , which shows that there is a latent possibility of an unpleasant discussion of the domain.

**D.** We solve the equation by the method of separation of the variables, either by means of theorem 1.1 or by some manipulation. The constant is then determined from the initial condition. Finally we must go through the discussion of the domain.

**I. First solution.** *Application of theorem 1.1.*

Since  $\psi(x) = x^{\frac{2}{3}} \neq 0$  for  $x \neq 0$ , we get

$$\begin{cases} G(x) = \int \frac{1}{\psi(x)} dx = \int x^{-\frac{2}{3}} dx = 3x^{\frac{1}{3}}, \\ F(t) = \int \varphi(t) dt = \int \sin t dt = -\cos t. \end{cases}$$

The solution is then implicitly given by

$$3x^{\frac{1}{3}} = -\cos t + c, \quad x \neq 0,$$

supplied with the trivial solution  $x = 0$ , and strictly speaking, also every differentiable compositions of such solutions for  $x = 0$ , if such compositions exist. This is, however, a very difficult discussion, which I shall leave out here.

When  $(t, x) = (0, 1)$ , we get  $3 = -1 + c$ , i.e.  $c = 4$ , and the solution is determined by

$$3x^{\frac{1}{3}} = 4 - \cos t > 0, \quad t \in \mathbb{R},$$

because the right hand side clearly is positive for every  $t \in \mathbb{R}$ . This will give us the solution

$$x = \left( \frac{4 - \cos t}{3} \right)^3, \quad t \in \mathbb{R},$$

which immediately is seen to be periodic of period  $2\pi$ .

**Second solution.** *Some manipulation.*

We shall here neglect the trivial solution  $x = 0$ .

When we divide by  $3x^{\frac{2}{3}}$ ,  $x \neq 0$ , we get

$$\frac{1}{3} x^{-\frac{2}{3}} \frac{dx}{dt} = \frac{d}{dt} \left( x^{\frac{1}{3}} \right) = \frac{1}{3} \sin t,$$

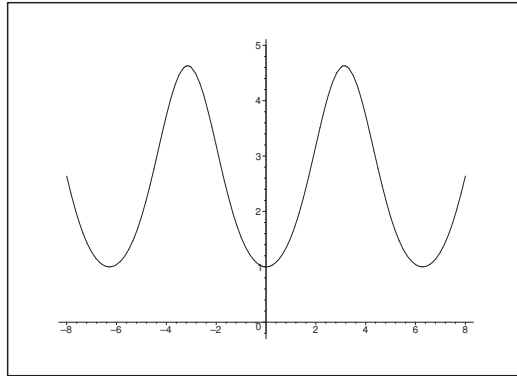

Figure 6: The solution curve  $x = \left(\frac{4 - \cos t}{3}\right)^3$ .

hence, by integration

$$x^{\frac{1}{3}} = -\frac{1}{3} \cos t + c.$$

When  $(t, x) = (0, 1)$ , we get  $1 = -\frac{1}{3} + c$ , i.e.  $c = \frac{4}{3}$ , from which

$$x^{\frac{1}{3}} = \frac{4 - \cos t}{3} \geq 1 \quad \text{for every } t \in \mathbb{R},$$

thus  $x \neq 0$ . The solution is uniquely given by

$$x = \left(\frac{4 - \cos t}{3}\right)^3, \quad t \in \mathbb{R}.$$

**C. TEST.** Let

$$x = \left(\frac{4 - \cos t}{3}\right)^3, \quad t \in \mathbb{R}.$$

Then  $x = 1$  for  $t = 0$ , so the initial condition is fulfilled.

Furthermore,

$$\frac{4 - \cos t}{3} = x^{\frac{1}{3}} > 0, \quad t \in \mathbb{R},$$

hence

$$\frac{dx}{dt} = 3 \left(\frac{4 - \cos t}{3}\right)^2 \frac{\sin t}{3} = \left(x^{\frac{1}{3}}\right)^2 \sin t = x^{\frac{2}{3}} \sin t,$$

and the solution has been checked.

**Example 2.5** . Find the complete solution of the differential equation

$$\frac{1}{x} \frac{dx}{dt} = 2^t, \quad t \in \mathbb{R}, \quad x > 0.$$

**A.** A first order differential equation, in which the variables can be separated. Integration of  $2^t$ .

**D.** Arrange the equation so that it suffices with only performing one integration.

**I.** The equation is written

$$\frac{1}{x} \frac{dx}{dt} = \frac{d \ln x}{dt} = 2^t = e^{t \ln 2}, \quad t \in \mathbb{R},$$

hence by an integration

$$\ln x = \frac{1}{\ln 2} e^{t \ln 2} + c = \frac{1}{\ln 2} 2^t + c, \quad t \in \mathbb{R},$$

and therefore, if we put  $C = e^c$ ,

$$x = \exp\left(\frac{1}{\ln 2} 2^t + c\right) = C \cdot \exp\left(\frac{1}{\ln 2} 2^t\right), \quad t \in \mathbb{R}, \quad C > 0.$$

Please click the advert

The advertisement features a collage of four images. The top-left image shows a person in a white shirt working at a computer workstation with a green chair. The top-right image shows two women in business attire; one is wearing a pink shirt and the other a white turtleneck, both smiling and talking. The bottom-left image shows a man in a dark suit holding a document. The bottom-right image shows a modern building with large glass windows illuminated at night. The entire collage is overlaid with a blue and white wavy graphic at the bottom.

[www.job.oticon.dk](http://www.job.oticon.dk)

**oticon**  
PEOPLE FIRST

Download free books at [BookBooN.com](http://BookBooN.com)



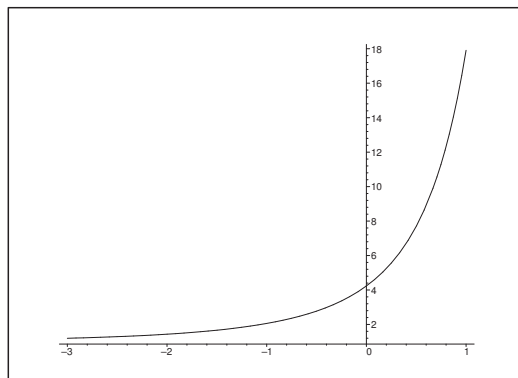

Figure 7: The curve  $x = \exp\left(\frac{1}{\ln 2} 2^t\right)$  for  $C = 1$ .

C. Let

$$x = C \cdot \exp\left(\frac{1}{\ln 2} 2^t\right), \quad C > 0, \quad t \in \mathbb{R}.$$

Then  $x > 0$  for every  $t \in \mathbb{R}$ , and

$$\frac{dx}{dt} = C \cdot \exp\left(\frac{1}{\ln 2} \cdot 2^t\right) \cdot \frac{1}{\ln 2} \cdot \ln 2 \cdot 2^t = x \cdot 2^t,$$

hence by a division by  $x = C \cdot \exp\left(\frac{1}{\ln 2} \cdot 2^t\right) > 0$ ,

$$\frac{1}{x} \frac{dx}{dt} = 2^t, \quad t \in \mathbb{R}, \quad x > 0,$$

and the solution has been checked.

**Example 2.6** . Consider the differential equation

$$\frac{dx}{dt} = 4(\sqrt[4]{x})^3, \quad t \in \mathbb{R}, \quad x \geq 0.$$

Prove by direct insertion that  $x = (t-1)^4$  is a solution for  $t \in [1, \infty[$ , but not a solution for  $t \in ]-\infty, 1[$ .

**A.** We shall not find the complete solution, but only show that some given function is a solution, while another one is not a solution. It would have been more correct to let  $t$  belong to open intervals. We are now forced to perform a limit.

**D.** Test the solutions by insertion.

**I.** Let  $x = (t-1)^4$  for  $t \in I$ , where  $I$  is one of the two open intervals  $]1, +\infty[$  or  $] -\infty, 1[$ . Then

$$\sqrt[4]{x} = |t-1| = \begin{cases} t-1 & \text{for } t \in ]1, +\infty[, \\ -(t-1) & \text{for } t \in ]-\infty, 1[. \end{cases}$$

and

$$\frac{dx}{dt} = 4(t-1)^3 = \begin{cases} 4(\sqrt[4]{x})^3, & \text{for } t \in ]1, +\infty[, \\ 4(-\sqrt[4]{x})^3 = -4(\sqrt[4]{x})^3 & \text{for } t \in ]-\infty, 1[, \end{cases}$$

which proved the claim for  $t \neq 1$ .

When  $t \rightarrow 1+$  from the right we get  $x = 0$ , and the derivative (the “half tangent”) is calculated,

$$\frac{x(t) - x(0)}{t - 1} = \frac{(t-1)^4}{t-1} = (t-1)^3 \rightarrow 0 = 4 \left( \sqrt[4]{x(0)} \right)^3 \quad \text{for } t \rightarrow 0+,$$

from which follows that  $x = (t-1)^4$  is a solution for  $t \in [1, +\infty[$  (by taking the limit to  $t = 1$ ) and not a solution for  $t \in ]-\infty, 1[$ .

REMARK. When  $x > 0$ , we divide the equation by  $4(\sqrt[4]{x})^3$  and get

$$\frac{1}{4} \frac{1}{(\sqrt[4]{x})} \frac{dx}{dt} = \frac{d\sqrt[4]{x}}{dt} = 1,$$

hence by an integration

$$\sqrt[4]{x} = t + c \quad (> 0),$$

The condition on the open domain is that  $t > -c$ . When this is the case, the complete solution is

$$x = (t+c)^4, \quad \text{for } t > -c, \quad c \in \mathbb{R} \text{ arbitrary. } \diamond$$

**Example 2.7** Find the complete solution  $x = f(t)$  of the differential equation

$$\frac{dx}{dt} + 2te^x = 0, \quad t \in \mathbb{R}, \quad x \in \mathbb{R},$$

for which  $f(2) = -\ln 3$ .

- A.** A differential equation of first order, where the variables can be separated.  
**D.** The equation is rearranged, and the variables are separated, e.g. by an application of theorem 1.1.  
 We get the constant from the initial condition. Discussion of the domain.

**I. First solution.** Application of theorem 1.1.

Since the equation can be written

$$\frac{dx}{dt} = -2te^x = \varphi(t)\psi(x), \quad t \in \mathbb{R}, \quad x \in \mathbb{R},$$

where

$$\varphi(t) = 2t \quad \text{and} \quad \psi(x) = e^{-x} \neq 0 \quad \text{for every } x,$$

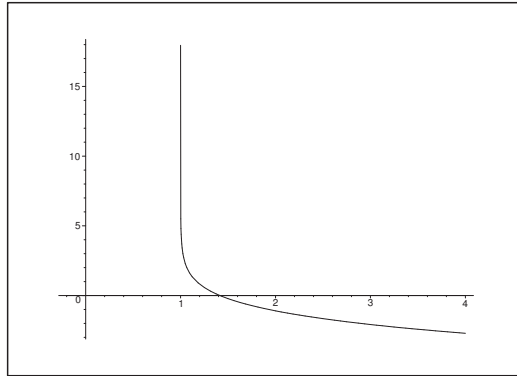

Figure 8: The solution curve  $x = -\ln(t^2 - 1)$  for  $t > 1$ .

we get

$$\begin{cases} G(x) = \int \frac{1}{\psi(x)} dx = -\int e^{-x} dx = e^{-x}, \\ F(t) = \int 2t dt = t^2. \end{cases}$$

Then by theorem 1.1 the complete solution is given by

$$e^{-x} = t^2 + c \quad (> 0), \quad c \in \mathbb{R}, \quad t \in I_c,$$

where each  $t \in I_c$  must satisfy the condition  $t^2 + c > 0$ .

When  $(t, x) = (2, -\ln 3)$ , we get  $c = -1$ , i.e. the solution is implicitly given by

$$e^{-x} = t^2 - 1 \quad (> 0), \quad \text{for } t > 0.$$

By taking the logarithm and changing the sign we get the explicit solution

$$x = -\ln(t^2 - 1), \quad \text{for } t > 1.$$

**Second solution.** *Reformulation followed by an integration.*

First we write the equation as

$$\frac{dx}{dt} = -2t e^x.$$

Dividing by  $-e^x$  we get

$$-e^{-x} \frac{dx}{dt} = \frac{d}{dt} (e^{-x}) = 2t,$$

hence by an integration,

$$e^{-x} = t^2 + c, \quad c \in \mathbb{R}, \quad t \in I_c,$$

where each  $t \in I_c$  must satisfy the condition  $t^2 + c > 0$ .

For  $(t, x) = (2, -\ln 3)$  we get  $c = -1$ , thus

$$e^{-x} = t^2 - 1 > 0, \quad \text{for } t > 1,$$

and therefore,

$$x = -\ln(t^2 - 1) = \ln\left(\frac{1}{t^2 - 1}\right), \quad \text{for } t \in \mathbb{R}.$$

C. TEST. Let  $x = -\ln(t^2 - 1)$  for  $t > 1$ . Then  $t^2 - 1 = e^{-x}$ , and

$$\frac{dx}{dt} = -\frac{2t}{t^2 - 1} = -\frac{2t}{e^{-x}} = -2t e^x,$$

which we rewrite as

$$\frac{dx}{dt} + 2t e^x = 0,$$

and we see that the differential equation is fulfilled.

Please click the advert



# CHALLENGE YOURSELF

## WWW.STUDYINSWEDEN.SE

Today's job market values ambitious, innovative, perceptive team players. Swedish universities foster these qualities through a forward-thinking culture where you're close to the latest ideas and global trends.

Whatever your career goals may be, studying in Sweden will give you valuable skills and a competitive advantage for your future. [www.studyinsweden.se](http://www.studyinsweden.se)

**Si.**  
Swedish Institute

Download free books at BookBooN.com

When  $t = 2$  is put into the expression of  $x$ , we get

$$x(2) = -\ln(2^2 - 1) = -\ln 3,$$

and we see that the initial condition is also satisfied.

We have checked our solution.

**Example 2.8** Find the complete solution of the differential equation

$$\frac{dx}{dt} + x \tan t = 0, \quad t \in \left] -\frac{\pi}{2}, \frac{\pi}{2} \right[.$$

**A.** The equation can either be solved by separating the variables, or as a linear equation of first order, where we have a solution formula. Finally it can be solved by the nasty trick of first dividing by  $\cos t$  and then manipulate the result in a clever way.

**D.** Choose one of the solution methods mentioned above.

**I. First solution.** Separation and theorem 1.1.

Rewrite the equation in the following way

$$\frac{dx}{dt} = -x \tan t = \varphi(t) \psi(x),$$

where

$$\varphi(t) = -\tan t \quad \text{and} \quad \psi(x) = x.$$

Then  $x = 0$  is trivially a solution, and we see that when  $x \neq 0$ , then  $\psi(x) \neq 0$ .

For  $x \neq 0$  we get

$$\begin{cases} G(x) &= \int \frac{1}{\psi(x)} dx = \int \frac{1}{x} dx = \ln |x|, \\ F(t) &= -\int \tan t dt = -\int \frac{\sin t}{\cos t} dt \\ &= \int \frac{d \cos t}{\cos t} = \ln \cos t, \end{cases}$$

because  $\cos t > 0$  for  $t \in \left] -\frac{\pi}{2}, \frac{\pi}{2} \right[$ .

According to theorem 1.1 the complete solution is for  $x \neq 0$  given by

$$\ln |x| = \ln \cos t + k, \quad x \neq 0, \quad k \in \mathbb{R}, \quad t \in I_k,$$

hence

$$|x| = e^k \cos t > 0, \quad k \in \mathbb{R}, \quad t \in \left] -\frac{\pi}{2}, \frac{\pi}{2} \right[,$$

thus with a new constant  $c = \pm e^k \neq 0$ , where we have built the sign of  $x$  into the constant  $c$ ,

$$x = c \cdot \cos t, \quad c \in \mathbb{R} \setminus \{0\}, \quad t \in \left] -\frac{\pi}{2}, \frac{\pi}{2} \right[.$$

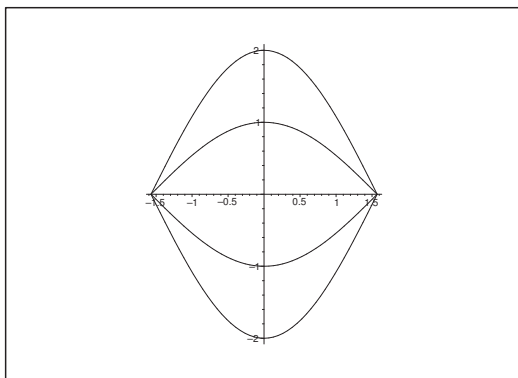

Figure 9: The solution curves  $x = c \cdot \cos t$ ,  $t \in \left] -\frac{\pi}{2}, \frac{\pi}{2} \right[$ , for  $c = -2, -1, 0, 1$  and  $2$ .

None of these solutions takes on the value 0, so we have no composition problems. Since  $x = 0$ , corresponding to  $c = 0$ , is also a solution, the complete solution is given by

$$x = c \cdot \cos t, \quad c \in \mathbb{R}, \quad t \in \left] -\frac{\pi}{2}, \frac{\pi}{2} \right[.$$

**Second solution.** *Reformulation followed by an integration.*

It follows trivially from

$$\frac{dx}{dt} = -x \tan t$$

that  $x = 0$  is a solution.

Now,  $\cos t > 0$  for  $t \in \left] -\frac{\pi}{2}, \frac{\pi}{2} \right[$ , so when also  $x \neq 0$ , we get

$$\frac{1}{x} \frac{dx}{dt} = \frac{d \ln |x|}{dt} = -\frac{\sin t}{\cos t} = \frac{1}{\cos t} \frac{d}{dt} \cos t = \frac{d}{dt} \ln \cos t.$$

Hence by an integration,

$$\ln |x| = \ln \cos t + k,$$

i.e. by the exponential function

$$|x| = e^k \cos t, \quad \text{or} \quad x = \pm e^k \cos t.$$

Since every real number  $c$  can either be written as  $\pm e^k$  for some  $k \in \mathbb{R}$  or as 0, and since  $c = 0$  corresponds to the solution  $x = 0$ , the complete solution must be given by

$$x = c \cdot \cos t, \quad c \in \mathbb{R}, \quad t \in \left] -\frac{\pi}{2}, \frac{\pi}{2} \right[.$$

**Third solution.** *A trick.*

When the equation is divided by  $\cos t > 0$ , and the equation then is read from the right towards the left, we get

$$\begin{aligned} 0 &= \frac{1}{\cos t} \frac{dx}{dt} + \frac{\sin t}{\cos^2 t} \cdot x = \frac{1}{\cos t} \frac{dx}{dt} - \frac{1}{\cos^2 t} \frac{d}{dt} (\cos t) \cdot x \\ &= \left( \frac{1}{\cos t} \right) \cdot \frac{dx}{dt} + \frac{d}{dt} \left( \frac{1}{\cos t} \right) \cdot x = \frac{d}{dt} \left( \frac{x}{\cos t} \right). \end{aligned}$$

Then by a simple integration,

$$\frac{x}{\cos t} = c, \quad c \in \mathbb{R}, \quad t \in \left] -\frac{\pi}{2}, \frac{\pi}{2} \right[ ,$$

and the complete solution is

$$x = c \cdot \cos t, \quad c \in \mathbb{R}, \quad t \in \left] -\frac{\pi}{2}, \frac{\pi}{2} \right[ .$$

**Fourth solution.** *Linear homogeneous differential equation of first order.*

We first get by an identification that  $p(t) = \tan t$ , hence

$$P(t) = \int \tan t \, dt = \int \frac{\sin t}{\cos t} \, dt = -\ln \cos t,$$

Please click the advert

## Turning a challenge into a learning curve. Just another day at the office for a high performer.

### Accenture Boot Camp – your toughest test yet

Choose Accenture for a career where the variety of opportunities and challenges allows you to make a difference every day. A place where you can develop your potential and grow professionally, working alongside talented colleagues. The only place where you can learn from our unrivalled experience, while helping our global clients achieve high performance. If this is your idea of a typical working day, then Accenture is the place to be.

It all starts at Boot Camp. It's 48 hours that will stimulate your mind and enhance your career prospects. You'll spend time with other students, top Accenture Consultants and special guests. An inspirational two days

packed with intellectual challenges and activities designed to let you discover what it really means to be a high performer in business. We can't tell you everything about Boot Camp, but expect a fast-paced, exhilarating

and intense learning experience. It could be your toughest test yet, which is exactly what will make it your biggest opportunity.

Find out more and apply online.

**Visit [accenture.com/bootcamp](https://www.accenture.com/bootcamp)**

• Consulting • Technology • Outsourcing

**accenture**  
*High performance. Delivered.*

where we again use that  $\cos t > 0$  for  $t \in ]-\frac{\pi}{2}, \frac{\pi}{2}[$ . Then the complete solution is obtained from theorem 1.2,

$$x = c \cdot e^{-P(t)} = c \cdot e^{\ln \cos t} = c \cdot \cos t, \quad c \in \mathbb{R}, \quad t \in ]-\frac{\pi}{2}, \frac{\pi}{2}[.$$

**C. TEST.** Let  $x = c \cdot \cos t$ ,  $c \in \mathbb{R}$ ,  $t \in ]-\frac{\pi}{2}, \frac{\pi}{2}[$ . Then

$$\frac{dx}{dt} + x \tan t = -c \cdot \sin t + c \cdot \cos t \cdot \frac{\sin t}{\sin t} = 0,$$

and we have checked our solution.

**Example 2.9** Find the complete solution of the differential equation

$$\frac{dx}{dt} = \frac{2t}{e^x}, \quad t \in \mathbb{R}, \quad x \in \mathbb{R}.$$

**A.** A non-linear first order differential equation, in which the variables can be separated.

**D.** Separate the variables and integrate. Discuss the intervals of the domain.

**I.** By separation of the variables we get

$$e^x dx = 2t dt, \quad \left[ \text{alternatively } e^x \frac{dx}{dt} = \frac{(e^x)}{dt} = 2t \right],$$

hence by an integration,

$$e^x = t^2 + c, \quad t^2 > -c,$$

so

$$x = \ln(t^2 + c), \quad \text{when } t^2 > -c.$$

When  $c = a^2 > 0$ , the solution is

$$x = \ln(t^2 + a^2), \quad t \in \mathbb{R},$$

defined for every  $t \in \mathbb{R}$ .

When  $c = -a^2$ ,  $a \geq 0$ , the solution is

$$x = \ln(t^2 - a^2) \quad \text{for either } t > a \text{ or } t < -a,$$

i.e. the solution is defined in two disjoint intervals, and it tends towards  $-\infty$ , when one is approaching the finite boundary point (and of course towards  $+\infty$ , when one let  $t$  tend towards infinity).

**C. TEST.** Let  $x = \ln(t^2 + c)$ , where  $t^2 > -c$ . Then

$$\frac{dx}{dt} = \frac{2t}{t^2 + c} = \frac{2t}{e^x},$$

in all cases.

We have checked our solution.



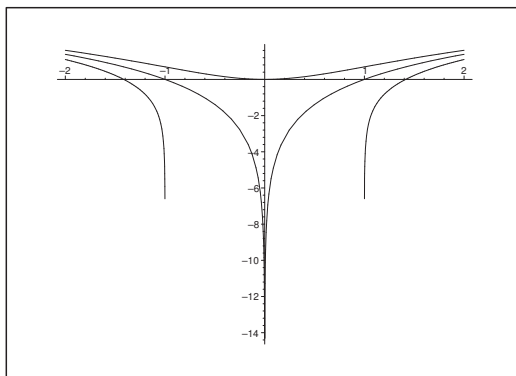

Figure 10: Sketch of the curves  $x = \ln(t^2 + c)$  for  $c = 1$  (above),  $c = 0$  (in the middle) and  $c = -1$  (below).

**Example 2.10** Find the complete solution of the differential equation

$$\frac{dx}{dt} = \frac{t}{x}, \quad x > 0, \quad t \in \mathbb{R}.$$

(Notice that this formulation implicitly requires that one shall indicate the domain of each solution). Sketch in the same coordinate system some solution curves, so we can obtain an overview of the set of all solution curves.

- A. A non-linear differential equation of first order, in which the variables can be separated.  
 D. Separate the variables and integrate. Discuss the intervals of the domain.  
 I. When the equation is multiplied by  $2x > 0$ , we get by a reformulation that

$$2x \frac{dx}{dt} = \frac{d(x^2)}{dt} = 2t,$$

which can be integrated immediately,

$$x^2 = t^2 + c \quad \text{for } t^2 > -c,$$

because  $x^2 > 0$  by the assumption.

- 1) When  $c = a^2 > 0$ , we get the solution

$$x = \sqrt{t^2 + a^2}, \quad t \in \mathbb{R},$$

which is defined in the whole of  $\mathbb{R}$ .

- 2) When  $c = 0$ , we get

$$x = t \text{ for } t > 0, \quad \text{or} \quad x = -t \text{ for } t < 0.$$

- 3) When  $c = -a^2 < 0$ , we get

$$x = \sqrt{t^2 - a^2} \quad \text{for} \quad \begin{cases} t > a, \\ t < -a. \end{cases}$$

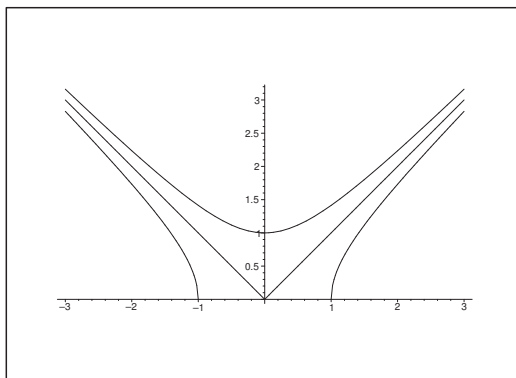

Figure 11: The graphs of  $x = \sqrt{t^2 + c}$  for  $c = 1$  (above),  $c = 0$  (the straight half lines in the middle) and for  $c = -1$  (below).

The curves are a part of a hyperbolic system in the open upper half plane, supplied by halves of the asymptotes.

**Example 2.11** Find in an explicit form the complete solution (including a discussion of the domains) of the differential equation

$$\frac{dx}{dt} = \frac{1}{2} \sqrt[3]{\frac{x}{t^2}}, \quad t > 0, \quad x > 0.$$

Sketch the solution, the graph of which goes through the point  $(1, 1)$ .

- A. A differential equation in which the variables can be separated. Find the complete solution and sketch one of these.
- D. Separate the variables and solve the equation (theorem 1.1). Do not forget to discuss the domains! Insert the initial condition and sketch the graph of the solution.
- I. When the equation is divided by  $\frac{3}{2} \sqrt[3]{x}$ ,  $x > 0$ , we get

$$\frac{2}{3} x^{-\frac{1}{3}} \frac{dx}{dt} = \frac{d}{dt} \left( x^{\frac{2}{3}} \right) = \frac{1}{3} t^{-\frac{2}{3}} = \frac{d}{dt} \left( t^{\frac{1}{3}} \right), \quad x > 0, \quad t > 0.$$

By an integration we get

$$(4) \quad x^{\frac{2}{3}} = t^{\frac{1}{3}} + c, \quad x > 0, \quad c \in \mathbb{R}, \quad t \in I_c \subseteq \mathbb{R}_+,$$

where  $t \in I_c$  satisfies  $t^{\frac{1}{3}} + c > 0$  and  $t > 0$ , i.e.  $t > -c^3$  and  $t > 0$ .

- 1) When  $c \geq 0$ , then  $t > -c^3$  for all  $t \in \mathbb{R}_+$ , hence  $I_c = \mathbb{R}_+$  in this case.
- 2) When  $c < 0$ , we get the domain

$$I_c = ]-c^3, +\infty[ = ]|c|^3, +\infty[.$$

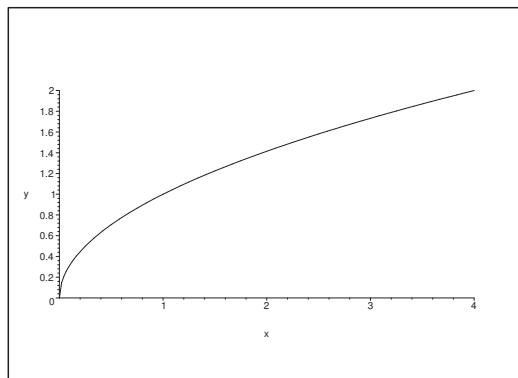

Figure 12: The solution curve through (1, 1).

Since  $x > 0$ , we finally get from (4) that the solution is given by

$$x = \left(t^{\frac{1}{3}} + c\right)^{\frac{3}{2}}, \quad \text{for } \begin{cases} t \in \mathbb{R}_+, & \text{when } c \geq 0, \\ t \in ]|c|^3, +\infty[ , & \text{when } c < 0. \end{cases}$$

When  $(t, x) = (1, 1)$ , it follows from (4) that

$$c = x^{\frac{2}{3}} - t^{\frac{1}{3}} = 1 - 1 = 0.$$

Hence the solution is

$$x = \sqrt{t}, \quad t \in \mathbb{R}_+.$$

C. When

$$x = \left(t^{\frac{1}{3}} + c\right)^{\frac{3}{2}}, \quad t \in I_c,$$

we get

$$\frac{dx}{dt} = \frac{3}{2} \cdot \left(t^{\frac{1}{3}} + c\right)^{\frac{1}{2}} \cdot \frac{1}{3} t^{-\frac{2}{3}} = \frac{1}{2} \sqrt[3]{\frac{1}{t^2} \left(t^{\frac{1}{3}} + c\right)^3} = \frac{1}{2} \sqrt[3]{\frac{x}{t^2}}.$$

We have checked our solution.

**Example 2.12** . Find the solution of the differential equation

$$e^{\sqrt{x}} \frac{dx}{dt} = 4t\sqrt{x}, \quad x > 0, \quad t \in \mathbb{R},$$

the graph of which goes through the point  $(-3, (\ln 5)^2)$ . Find in particular the domain of this solution.

A. A non-linear differential equation of first order with an initial condition, and where the variable can be separated.

D. Separate the variables and solve the equation. Then insert the initial condition and find the wanted particular solution.

Do not forget to discuss the domain.

I. When we divide by  $2\sqrt{x} > 0$  we get

$$2t = e^{\sqrt{x}} \cdot \frac{1}{2\sqrt{x}} \frac{dx}{dt} = e^{\sqrt{x}} \frac{d}{dt} (\sqrt{x}) = \frac{d}{dt} (e^{\sqrt{x}}).$$

Then by an integration

$$e^{\sqrt{x}} = t^2 + c, \quad c \in \mathbb{R}, \quad x > 0, \quad t \in I_c.$$

Since  $e^{\sqrt{x}} > 1$  for  $x > 0$ , we conclude that  $t \in I_c$  must satisfy  $t^2 + c > 1$ , i.e.  $t^2 > 1 - c$ .

When  $(t, x) = (-3, (\ln 5)^2)$ , we get

$$c = e^{\sqrt{x}} - t^2 = e^{\ln 5} - (-3)^2 = 5 - 9 = -4,$$

Please click the advert





it's an **interesting** world

## Get under the skin of it.

**Graduate opportunities**  
**Cheltenham | £24,945 + benefits**

One of the UK's intelligence services, GCHQ's role is two-fold: to gather and analyse intelligence which helps shape Britain's response to global events, and, to provide technical advice for the protection of Government communication and information systems. In doing so, our specialists – in IT, internet, engineering, languages, information assurance, mathematics and intelligence – get well beneath the surface of global affairs. If you thought the world was an interesting place, you really ought to explore our world of work.

[www.careersinbritishintelligence.co.uk](http://www.careersinbritishintelligence.co.uk)

Applicants must be British citizens. GCHQ values diversity and welcomes applicants from all sections of the community. We want our workforce to reflect the diversity of our work.







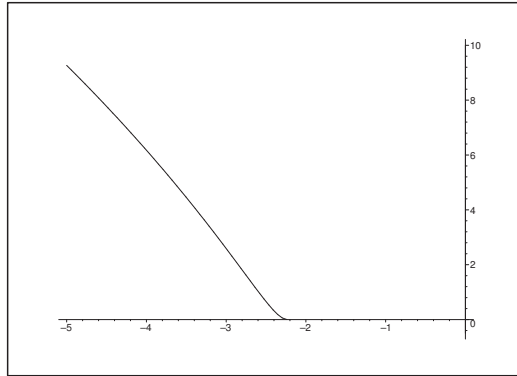

Figure 13: The wanted solution through the point  $(-3, (\ln 5)^2)$ .

so we have derived the condition

$$t^2 > 1 - c = 1 - (-4) = 5, \quad \text{or} \quad |t| > \sqrt{5}.$$

Therefore, the solution

$$x = \{\ln(t^2 + c)\}^2 = \{\ln(t^2 - 4)\}^2$$

is defined in the two intervals  $]-\infty, -\sqrt{5}[$  and  $]\sqrt{5}, +\infty[$ . Since  $t = -3 \in ]-\infty, -\sqrt{5}[$  for the given initial point, the wanted solution is

$$x = \{\ln(t^2 - 4)\}^2, \quad t \in ]-\infty, -\sqrt{5}[.$$

C. When

$$x = f(t) = \{\ln(t^2 - 4)\}^2, \quad t \in ]-\infty, -\sqrt{5}[,$$

we see that  $t = -3$  lies in the interval and

$$f(-3) = \{\ln((-3)^2 - 4)\}^2 = (\ln 5)^2,$$

hence the initial condition is satisfied.

Then note that since  $t^2 - 4 > 1$  for  $t < \sqrt{5}$ , we have

$$\sqrt{x} = +\ln(t^2 - 4), \quad t < \sqrt{5},$$

thus

$$e^{\sqrt{x}} \frac{dx}{dt} = e^{\ln(t^2 - 4)} \cdot 2 \ln(t^2 - 4) \cdot \frac{2t}{t^2 - 4} = (t^2 - t) \cdot \sqrt{x} \cdot \frac{4t}{t^2 - 4} = 4t \sqrt{x},$$

and we have checked our solution.

**Example 2.13** Find the solution  $x = \varphi(t)$  of the differential equation

$$\frac{dx}{dt} = \frac{1+x^2}{1+t^2},$$

for which  $\varphi(0) = 1$ .

*Hint: Use that*

$$\tan(u+v) = \frac{\tan u + \tan v}{1 - \tan u \tan v}.$$

**A.** A non-linear differential equation of first order which can be solved by separation.

**D.** Divide by  $1+x^2 > 0$  and integrate. Insert  $t = 0$  and find the constant. Discuss the domain.

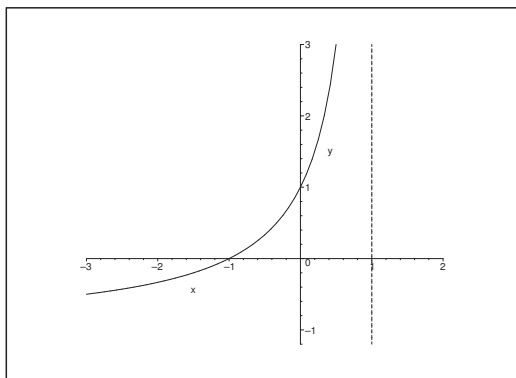

Figure 14: The solution curve  $x = \frac{1+t}{1-t}$ ,  $t < 1$ , with the vertical asymptote  $t = 1$ .

**I.** By a division by  $1+x^2$  followed by a reformulation we get

$$\frac{1}{1+t^2} = \frac{1}{1+x^2} \frac{dx}{dt} = \frac{d}{dt} \text{Arctan } x,$$

hence by an integration,

$$\text{Arctan } x = \int \frac{1}{1+t^2} dt + c = \text{Arctan } t + c.$$

When  $t = 0$  we get

$$\text{Arctan } x(0) = \text{Arctan } 1 = \frac{\pi}{4} = \text{Arctan } 0 + c = c,$$

i.e.  $c = \frac{\pi}{4}$ , and

$$\text{Arctan } x(t) = \text{Arctan } t + \frac{\pi}{4}.$$

By solving this equation with respect to  $x$  we get

$$\begin{aligned} x(t) &= \tan(\operatorname{Arctan} x(t)) = \tan \left\{ \operatorname{Arctan} t + \frac{\pi}{4} \right\} \\ &= \frac{\tan(\operatorname{Arctan} t) + \tan \frac{\pi}{4}}{1 - \tan(\operatorname{Arctan} t) \cdot \tan \frac{\pi}{4}} = \frac{t+1}{1-t}, \end{aligned}$$

and the solution is

$$x = \frac{1+t}{1-t}, \quad \text{for } t < 1,$$

because we require that  $t \neq 1$  (the denominator is  $\neq 0$ ), and because  $t = 0$  must belong to the domain.

C. TEST. When

$$x = \frac{1+t}{1-t} = \frac{2}{1-t} - 1, \quad \text{for } t < 1,$$

we get  $x(0) = \frac{1+0}{1-0} = 1$ , and

$$\frac{dx}{dt} = \frac{d}{dt} \left\{ \frac{2}{1-t} - 1 \right\} = \frac{2}{(1-t)^2},$$

Please click the advert



**Brain power**

By 2020, wind could provide one-tenth of our planet's electricity needs. Already today, SKF's innovative know-how is crucial to running a large proportion of the world's wind turbines.

Up to 25 % of the generating costs relate to maintenance. These can be reduced dramatically thanks to our systems for on-line condition monitoring and automatic lubrication. We help make it more economical to create cleaner, cheaper energy out of thin air.

By sharing our experience, expertise, and creativity, industries can boost performance beyond expectations. Therefore we need the best employees who can meet this challenge!

**The Power of Knowledge Engineering**

Plug into The Power of Knowledge Engineering.  
Visit us at [www.skf.com/knowledge](http://www.skf.com/knowledge)

**SKF**

and

$$\begin{aligned}\frac{1+x^2}{1+t^2} &= \frac{1}{1+t^2} \left\{ 1 + \left( \frac{1+t}{1-t} \right)^2 \right\} = \frac{1}{1+t^2} \cdot \frac{(1-t)^2 + (1+t)^2}{(1-t)^2} \\ &= \frac{1}{1+t^2} \cdot \frac{2+2t^2}{(1-t)^2} = \frac{2}{(1-t)^2} = \frac{dx}{dt},\end{aligned}$$

and we have checked our solution.

**Example 2.14** Consider the differential equation

$$(5) \quad \frac{dx}{dt} = 3x^3 \sqrt{t}, \quad t \geq 0, \quad x > 0.$$

- 1) Find the solution  $x = \varphi(t)$  of (5), for which  $\varphi(1) = \frac{1}{\sqrt{28}}$ . Sketch the graph of  $\varphi(t)$ .
- 2) Show by direct insertion in (5), that the found  $\varphi(t)$  indeed is a solution.
- 3) Show that every solution of (5) has a vertical asymptote.

**A.** A differential equation in which the variables can be separated. The problem is subdivided into three questions:

- 1) Find one particular solution.
- 2) Test the solution.
- 3) Discuss the asymptotes.

**D.** 1) The equation is solved by the method of separation of the variables, e.g. by an application of theorem 1.1. Then we get our solution by means of the initial condition. Do not forget to sketch the curve.

- 2) Test the particular solution.
- 3) The investigation of the asymptotes is done by some limit.

**I.** 1) **First variant.** Application of theorem 1.1.

It follows from

$$\frac{dx}{dt} = f(t)g(x), \quad f(t) = \sqrt{t}, \quad g(x) = 3x^3 \neq 0, \quad t \geq 0, \quad x > 0,$$

that

$$\left\{ \begin{array}{l} G(x) = \int \frac{1}{g(x)} dx = \int \frac{1}{3} x^{-3} dx = -\frac{1}{6} \frac{1}{x^2}, \\ F(t) = \int f(t) dt = \int t^{\frac{1}{2}} dt = \frac{2}{3} t^{\frac{3}{2}} = \frac{2}{3} t \sqrt{t}. \end{array} \right.$$



We get the complete solution in an implicit form by applying theorem 1.1,

$$-\frac{1}{6} \frac{1}{x^2} = \frac{2}{3} t \sqrt{t} + k, \quad t \in I_k, \quad k \in \mathbb{R}.$$

The requirement of  $t \in I_k$  is that  $t \geq 0$  and  $\frac{2}{3} t \sqrt{t} + k < 0$ , i.e.  $(\sqrt{t})^3 < -\frac{3}{2} k$ , hence  $k < 0$  and

$$0 \leq t < \left(-\frac{3}{2} k\right)^{\frac{2}{3}} \quad \text{for } t \in I_k.$$

Since  $k = -\left\{\frac{1}{6} \frac{1}{x^2} + \frac{2}{3} t \sqrt{t}\right\}$  we get for  $(t, x) = \left(1, \frac{1}{\sqrt{28}}\right)$ ,

$$k = -\left\{\frac{28}{6} + \frac{2}{3}\right\} = -\frac{16}{3},$$

i.e.

$$-\frac{1}{6} \frac{1}{x^2} = \frac{2}{3} t \sqrt{t} - \frac{16}{3} \quad \text{for } t \in I_k,$$

where  $I_k$  is determined by  $t \geq 0$  and  $\frac{2}{3} t \sqrt{t} < \frac{16}{3}$ , i.e.  $(\sqrt{t})^3 < 8$ , from which  $t < 4$ . Therefore, the domain is  $I_k = [0, 4[$ . Then

$$\frac{1}{x^2} = 32 - 4t \sqrt{t} = 4 \left\{8 - t^{\frac{3}{2}}\right\}, \quad t \in [0, 4[.$$

Finally, since we have assumed that  $x > 0$ ,

$$x = \frac{1}{2} \frac{1}{\sqrt{8 - t^{3/2}}}, \quad t \in [0, 4[.$$

**Second variant.** When we divide by  $-\frac{1}{2} x^3$  we get

$$-6t^{\frac{1}{2}} = -2x^{-3} \frac{dx}{dt} = \frac{d}{dt} \left(\frac{1}{x^2}\right).$$

Then by an integration,

$$\frac{1}{x^2} = -6 \int t^{\frac{1}{2}} dt + 4c = -6 \cdot \frac{2}{3} t^{\frac{3}{2}} + 4c = -4t^{\frac{3}{2}} + 4c.$$

Since  $x > 0$  and  $t \geq 0$ , we must have  $-4t^{\frac{3}{2}} + 4c > 0$  in the domain, i.e. we only get solutions, when  $c > 0$ . In that case ( $x > 0$ ) we have

$$x = \frac{1}{\sqrt{4c - 4t^{3/2}}} = \frac{1}{2} \cdot \frac{1}{\sqrt{c - t^{3/2}}}, \quad t \in [0, c^{2/3}[.$$

When  $(t, x) = \left(1, \frac{1}{\sqrt{28}}\right)$  is put into the equation, we get  $4c = \frac{1}{x^2} + 4t^{3/2}$ , thus

$$c = \frac{28 + 4}{4} = \frac{32}{4} = 8 = 2^3,$$

i.e.  $I_c = [0, 8^{2/3}[ = [0, 4[$ , and we have found the solution

$$x = \frac{1}{2} \cdot \frac{1}{\sqrt{8 - t^{3/2}}}, \quad t \in [0, 4[.$$

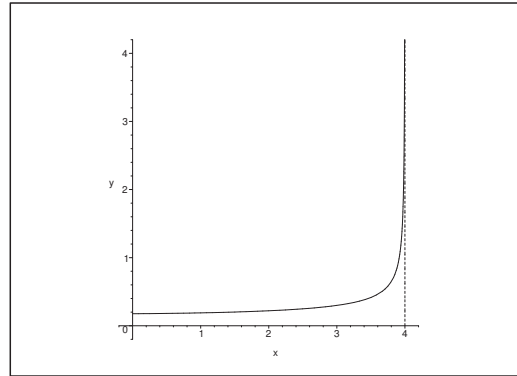

Figure 15: The graph of  $x = \frac{1}{2} \cdot \frac{1}{\sqrt{8 - t^{3/2}}}$ ,  $t \in [0, 4[$ , and its vertical asymptote  $x = 4$ .

## Trust and responsibility

NNE and Pharmaplan have joined forces to create NNE Pharmaplan, the world's leading engineering and consultancy company focused entirely on the pharma and biotech industries.

Inés Aréizaga Esteva (Spain), 25 years old  
Education: Chemical Engineer

– You have to be proactive and open-minded as a newcomer and make it clear to your colleagues what you are able to cope. The pharmaceutical field is new to me. But busy as they are, most of my colleagues find the time to teach me, and they also trust me. Even though it was a bit hard at first, I can feel over time that I am beginning to be taken seriously and that my contribution is appreciated.

Please click the advert



NNE Pharmaplan is the world's leading engineering and consultancy company focused entirely on the pharma and biotech industries. We employ more than 1500 people worldwide and offer global reach and local knowledge along with our all-encompassing list of services.  
[nnepharmaplan.com](http://nnepharmaplan.com)

nne pharmaplan®

SKETCH OF THE CURVE. The function  $x = \frac{1}{2} \cdot \frac{1}{\sqrt{8-t^{3/2}}}$ ,  $t \in [0, 4[$ , is trivially increasing, and for  $t \rightarrow 4-$  it tends towards  $+\infty$ , hence  $x = 4$  is a vertical asymptote.

2) C. Let

$$x = f(t) = \frac{1}{2} \frac{1}{\sqrt{8-t^{3/2}}}, \quad t \in [0, 4[.$$

Then  $f(t)$  is defined in the whole of the interval  $[0+, 4[$ .

For  $t = 1$  we get  $f(1) = \frac{1}{2} \frac{1}{\sqrt{7}} = \frac{1}{\sqrt{28}}$ .

Finally, we get by a differentiation

$$\begin{aligned} \frac{dx}{dt} &= \frac{1}{2} \cdot \left(-\frac{1}{2}\right) \cdot \frac{1}{\left(\sqrt{8-t^{3/2}}\right)^3} \cdot \left(-\frac{3}{2} \sqrt{t}\right) \\ &= 3 \left\{ \frac{1}{2} \frac{1}{\sqrt{8-t^{3/2}}} \right\}^3 \sqrt{t} = 3x^3 \sqrt{t}. \end{aligned}$$

We have checked our solution.

3) According to (1) the general solution has the form

$$x = \frac{1}{2} \frac{1}{\sqrt{c-t^{3/2}}}, \quad t \in \left[0, c^{2/3}\right[, \quad c > 0.$$

When  $t \rightarrow c^{2/3}-$ , we get  $\sqrt{c-t^{3/2}} \rightarrow 0+$ , from which we conclude that  $x = f(t) \rightarrow +\infty$  for  $t \rightarrow c^{2/3}-$ , and the solution has the vertical asymptote  $t = c^{2/3}$ .

**Example 2.15** Find the solution  $x = \varphi(t)$  of the differential equation

$$\frac{dx}{dt} = \frac{2t}{e^x}, \quad t \in \mathbb{R}, \quad x \in \mathbb{R},$$

for which  $\varphi(\sqrt{2}) = 0$ . Determine the domain of the solution.

A. A non-linear differential equation of first order, in which the variables can be separated.

D. Multiply by  $e^x$  and reduce.

I. By the multiplication by  $e^x$  we get

$$e^x = t^2 + c > 0,$$

i.e. the complete solution is given by

$$x = \ln(t^2 + c) \quad \text{for } t^2 + c > 0.$$

We get from  $\varphi(\sqrt{2}) = 0$  that

$$\exp(\varphi(\sqrt{2})) = 1 = (\sqrt{2})^2 + c = 2 + c,$$

so  $c = -1$ . Therefore, the solution is  $x = \ln(t^2 - 1)$  where  $|t| > 1$ . Furthermore, since  $t = \sqrt{2}$  must lie in the domain, the solution is

$$\varphi(t) = \ln(t^2 - 1), \quad \text{for } t > 1.$$

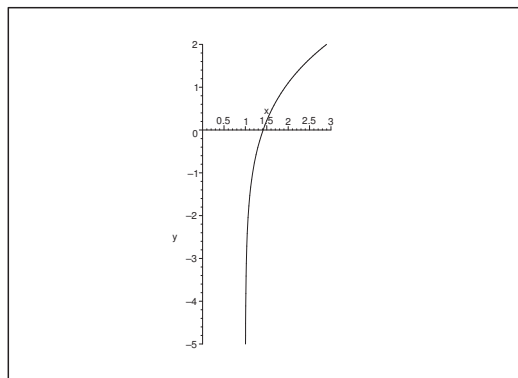

Figure 16: The solution  $\varphi(t) = \ln(t^2 - 1)$  for  $t > 1$ .

**Example 2.16** Find the complete solution of the differential equation

$$\frac{dx}{dt} = \frac{e^{-x}}{1+t^2}, \quad x \in \mathbb{R}, \quad t \in \mathbb{R}.$$

Specify the domain for each of the solutions.

- A. A non-linear differential equation of first order, in which the variables can be separated.
- D. Multiply by  $e^x$  and reduce.
- I. Multiplication by  $e^x$  gives

$$\frac{1}{1+t^2} = e^x \frac{dx}{dt} = \frac{d(e^x)}{dt},$$

hence by integration,

$$e^x = \text{Arctan } t + c.$$

The requirement of the domain is that

$$\text{Arctan } t + c > 0,$$

so the complete solution becomes

$$x = \ln(\text{Arctan } t + c), \quad \text{når } \text{Arctan } t + c > 0.$$

Since  $\text{Arctan } t \in \left] -\frac{\pi}{2}, \frac{\pi}{2} \right[$ , the domain is the whole of  $\mathbb{R}$ , when  $c \geq \frac{\pi}{2}$ , and empty when  $c \leq -\frac{\pi}{2}$ .

When  $c \in \left] -\frac{\pi}{2}, \frac{\pi}{2} \right[$ , we get the condition  $\text{Arctan } t > -c$ , thus  $t > -\tan c$ .

Summarizing we therefore get

- 1)  $x = \ln(\text{Arctan } t + c)$  for every  $t \in \mathbb{R}$ , when  $c \geq \frac{\pi}{2}$ ,

- 2)  $x = \ln(\text{Arctan } t + c)$  for  $t > -\tan c$ , when  $-\frac{\pi}{2} < c < \frac{\pi}{2}$ ,
- 3) no solution when  $c \leq -\frac{\pi}{2}$ .

**Example 2.17** Find the complete solution of the equation

$$\frac{dx}{dt} = (2x - 3)(t + 1), \quad t \in \mathbb{R}, \quad x \in \mathbb{R}.$$

Find the solution and its domain which is passing through (1, 1).

- A. A linear and inhomogeneous differential equation of first order.
- D. Even though the equation can be solved by using the usual solution formula for linear differential equations of first order. we see that the formulation of the equation invites to a solution by separating the variables.

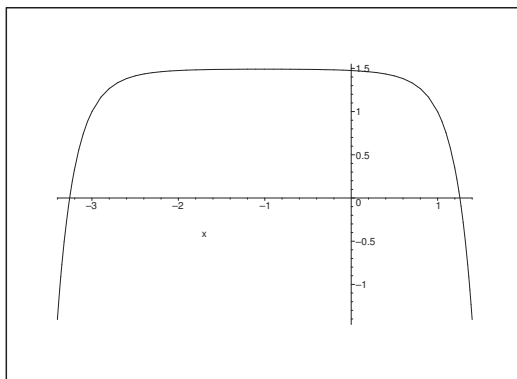

Figure 17: The graph of the solution curve through (1, 1).

- I. It is obvious that  $x = \frac{3}{2}$  is a particular solution. When  $x \neq \frac{3}{2}$ , we get by separating the variables that

$$\int \frac{dx}{x - \frac{3}{2}} = c_1 + \int 2(t + 1) dt,$$

i.e.

$$\ln \left| x - \frac{3}{2} \right| = c_1 + (t + 1)^2,$$

and the complete solution becomes

$$x = \frac{3}{2} + c \cdot \exp((t + 1)^2), \quad t \in \mathbb{R}, \quad c \in \mathbb{R}.$$

Notice that  $c = 0$  corresponds to the exceptional curve given by  $x = \frac{3}{2}$ .

The constant of the solution curve through  $(x, t) = (1, 1)$  is obtained by solving the equation

$$1 = \frac{3}{2} + c \cdot \exp((t+1)^2),$$

hence

$$c = -\frac{1}{2e^4}.$$

Therefore the wanted solution is defined for every  $t \in \mathbb{R}$ , and

$$\begin{aligned} x &= \frac{3}{2} - \frac{1}{2} \exp((t+1)^2 - 4) \\ &= \frac{3}{2} - \frac{1}{2} \exp((t+3)(t-1)), \quad t \in \mathbb{R}. \end{aligned}$$

Please click the advert

**THE MILKWAY**  
LAUNCHING GRADUATE CAREERS

**MILKROUND SYSTEM**  
Become a business star with internships, placements, graduate jobs & schemes from leading companies.  
[www.milkround.com](http://www.milkround.com)

**PLANET CAREER ADVICE**  
Inhabited by insights into business careers and orbited by application advice.

**FIRST CONTACT**  
Get matched to top business employers via intelligent emails landing in your inbox.

**Milkround.com: rated the #1 graduate recruitment website in the UK Graduate Careers Survey 2009 of 16,000 university finalists.**

**Milkround.com**

Download free books at [BookBooN.com](http://BookBooN.com)

### 3 Linear differential equation of first order

**Example 3.1** . Find the complete solution of the differential equation

$$\frac{dx}{dt} + x = t, \quad t \in \mathbb{R}.$$

- A.** The equation is a linear differential equation of first order.  
**D.** The equation can either be solved by the formulæ in theorem 1.2 and theorem 1.3, or by a multiplication by an “integrating factor”  $e^t$  followed by an integration.  
**I. First solution.** Application of theorem 1.2 and theorem 1.3.

Since  $p(t) = 1$ , we get

$$P(t) = \int p(t) dt = t,$$

and hence the complete solution of the corresponding homogeneous equation becomes

$$x = c \cdot e^{-t}, \quad t \in \mathbb{R}, \quad c \in \mathbb{R}.$$

Since  $q(t) = t$ , a particular solution is given by

$$\begin{aligned} x &= e^{-P(t)} \int e^{P(t)} q(t) dt = e^{-t} \int e^t \cdot t dt \\ &= e^{-t} \left\{ e^t \cdot t - \int e^t dt \right\} = e^{-t} \{ e^t \cdot t - e^t \} = t - 1. \end{aligned}$$

**VARIANT.** If we *guess* the structure  $x = at + b$  of the solution, we get by insertion (i.e. by testing) that

$$\frac{dx}{dt} + x = a + (at + b) = at + (a + b) = t,$$

which is fulfilled for  $a = 1$  and  $b = -1$ . Thus a particular solution is given by  $x = t - 1$ .

According to theorem 1.3 the complete solution is then

$$x = t - 1 + c \cdot e^{-t}, \quad c \in \mathbb{R}, \quad t \in \mathbb{R}.$$

**Second solution.** When the equation is multiplied by  $e^t$  and the result is read from the right towards the left, we get by a small reformulation that

$$t e^t = e^t \frac{dx}{dt} + e^t x = e^t \frac{dx}{dt} + \frac{d}{dt} (e^t) \cdot x = \frac{d}{dt} (x e^t),$$

where we apply the rule of differentiation of a product. The equation

$$\frac{d}{dt} (x e^t) = t e^t$$

is then solved by an integration:

$$x e^t = \int t e^t dt = t e^t - \int e^t dt = (t - 1)e^t + c,$$

hence

$$x = t - 1 + c \cdot e^{-t}, \quad c \in \mathbb{R}, \quad t \in \mathbb{R}.$$

**C. TEST.** Let  $x = t - 1 + c \cdot e^{-t}$ ,  $c \in \mathbb{R}$ ,  $t \in \mathbb{R}$ . By insertion in the differential equation we get

$$\frac{dx}{dt} + x = (1 - c \cdot e^{-t}) + (t - 1 + c \cdot e^{-t}) = t.$$

We have checked our solution.

**Example 3.2** Find the solution  $x = f(t)$  of the differential equation

$$\frac{dx}{dt} + \frac{1}{t}x = -2t^2, \quad t > 0,$$

for which  $f(1) = -1$ .

**A.** A linear inhomogeneous differential equation of first order.

**D.** The equation can either be solved by using theorem 1.2 and theorem 1.3, or by a small trick where one multiplies by  $t$  and reformulates the equation to a form which can be directly integrated.

**I. First solution.** Application of theorem 1.2 and theorem 1.3.

From  $p(t) = \frac{1}{t}$ ,  $t > 0$ , and  $q(t) = -2t^2$ , we get

$$P(t) = \int \frac{1}{t} dt = \ln t, \quad t > 0,$$

hence the complete solution of the homogeneous equation is

$$x = c \cdot e^{-\ln t} = \frac{c}{t}, \quad c \in \mathbb{R}, \quad t > 0.$$

A particular solution is given by

$$\begin{aligned} x &= e^{-P(t)} \int e^{P(t)} q(t) dt = \frac{1}{t} \int t \cdot (-2t^2) dt \\ &= -\frac{2}{t} \int t^3 dt = -\frac{2}{t} \cdot \frac{1}{4} t^4 = -\frac{1}{2} t^3. \end{aligned}$$

Then according theorem 1.3 the complete solution is

$$x = -\frac{1}{2} t^3 + \frac{c}{t}, \quad c \in \mathbb{R}, \quad t > 0.$$

ALTERNATIVELY we know that both differentiation and division by  $t > 0$  will lower the degree of a polynomial without a constant term by 1. In order to find a particular solution it will therefore be reasonable to guess a polynomial of degree  $2+1=3$ . Therefore, let  $x = at^3$ . Then

$$\frac{dx}{dt} + \frac{1}{t}x = 3at^2 + at^2 = 4at^2 = -2t^2,$$

from which  $a = -\frac{1}{2}$ , and  $x = -\frac{1}{2}t^3$  is a particular solution.

When the initial condition  $f(1) = -1$  is inserted into the general expression of the solution

$$f(t) = -\frac{1}{2}t^3 + \frac{c}{t},$$



we get  $-\frac{1}{2} + c = -1$ , from which  $c = -\frac{1}{2}$ , and the solution is

$$f(t) = -\frac{1}{2} \left( t^3 + \frac{1}{t} \right), \quad t > 0.$$

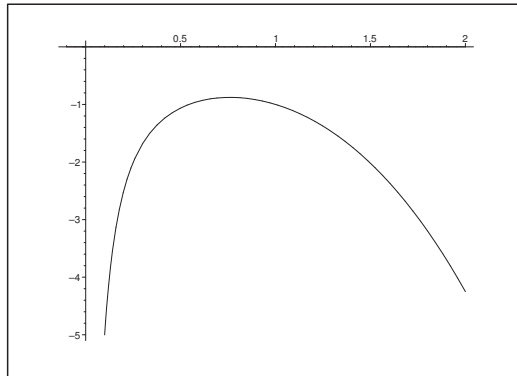

Figure 18: Graph of the solution  $x = -\frac{1}{2} \left( t^3 + \frac{1}{t} \right)$ ,  $t > 0$ .

**Second solution.** *Integrating factor.*

When the equation is multiplied by  $t > 0$  and then read from the right towards the left, we get by a small reformulation that

$$-2t^3 = t \frac{dx}{dt} + 1 \cdot x = t \cdot \frac{dx}{dt} + \frac{dt}{dt} \cdot x = \frac{d}{dt} (tx),$$

where we have used the rule of differentiation of a product. Then by an integration

$$tx = - \int 2t^3 dt + c = -\frac{1}{2} t^4 + c,$$

and the complete solution is obtained by a division by  $t > 0$ :

$$x = f(t) = -\frac{1}{2} t^3 + \frac{c}{t}, \quad c \in \mathbb{R}, \quad t > 0.$$

When  $t = 1$ , we get  $f(1) = -1 = -\frac{1}{2} + c$ , so  $c = -\frac{1}{2}$ . Therefore, our solution becomes

$$x = f(t) = -\frac{1}{2} \left( t^3 + \frac{1}{t} \right), \quad t > 0.$$

**C. TEST.** Let  $x = f(t) = -\frac{1}{2} \left( t^3 + \frac{1}{t} \right)$ ,  $t > 0$ .

For  $t = 1$  we get  $f(1) = -\frac{1}{2} (1 + 1) = -1$ .

By insertion in the left hand side of the differential equation we get

$$\begin{aligned}\frac{dx}{dt} + \frac{1}{t}x &= -\frac{1}{2}\left(3t^2 - \frac{1}{t^2}\right) + \frac{1}{t^2}\left(-\frac{1}{2}\right) \cdot \left(t^3 + \frac{1}{t}\right) \\ &= -\frac{1}{2}\left\{3t^2 - \frac{1}{t^2} + t^2 + \frac{1}{t^2}\right\} = -\frac{1}{2} \cdot 4t^2 = -2t^2.\end{aligned}$$

We have checked our solution.

Please click the advert



# CHALLENGE YOURSELF

## WWW.STUDYINSWEDEN.SE

Today's job market values ambitious, innovative, perceptive team players. Swedish universities foster these qualities through a forward-thinking culture where you're close to the latest ideas and global trends.

Whatever your career goals may be, studying in Sweden will give you valuable skills and a competitive advantage for your future. [www.studyinsweden.se](http://www.studyinsweden.se)

**Si.**  
Swedish Institute

Download free books at BookBooN.com

**Example 3.3** Find the complete solution of the differential equation

$$t \frac{dx}{dt} - 2x = t^5, \quad t < 0.$$

**A.** A non-normed linear inhomogeneous differential equation of first order. Notice that  $t < 0$ .

**D.** Here we have several possible methods of solution:

- 1) Norm the equation and solve by means of the formula in theorem 1.2.
- 2) Divide by  $t^3$  and rewrite the result as an integration problem.
- 3) Guess a polynomial and test.

**I. First solution.** Application of theorem 1.2.

We first norm the equation:

$$\frac{dx}{dt} - \frac{2}{t}x = t^4, \quad t < 0.$$

Here

$$p(t) = -\frac{2}{t}, \quad q(t) = t^4, \quad P(t) = -\int \frac{2}{t} dt = -2 \ln |t| = -\ln(t^2).$$

The complete solution is obtained by theorem 1.2:

$$\begin{aligned} x &= e^{-P(t)} \left\{ e^{P(t)} q(t) dt + c \right\} = t^2 \left\{ \int \frac{1}{t^2} \cdot t^4 dt + c \right\} \\ &= t^2 \left\{ \int t^2 dt + c \right\} = t^2 \left\{ \frac{1}{3} t^3 + c \right\} = \frac{1}{3} t^5 + c t^2, \end{aligned}$$

i.e.

$$x = \frac{1}{3} t^5 + c t^2, \quad c \in \mathbb{R}, \quad t < 0.$$

**Second solution.** A nice little reformulation.

When we read the equation from the right towards the left and divide it by  $t^3 \neq 0$ , we get by a small rearrangement that

$$t^2 = \frac{1}{t^2} \frac{dx}{dt} - \frac{2}{t^3} \cdot x = \frac{1}{t^2} \frac{dx}{dt} + \frac{d}{dt} \left( \frac{1}{t^2} \right) \cdot x = \frac{d}{dt} \left( \frac{x}{t^2} \right).$$

Therefore by an integration,

$$\frac{x}{t^2} = \int t^2 dt + c = \frac{1}{3} t^3 + c,$$

and the complete solution is

$$x = \frac{1}{3} t^5 + c \cdot t^2, \quad c \in \mathbb{R}, \quad t < 0.$$

**Third solution.** *Guess a polynomial.*

If  $x$  is a non-constant polynomial then both  $t \frac{dx}{dt}$  and  $2x$  are polynomials of the same degree. It is therefore quite reasonable to guess a solution of the form

$$x = a \cdot t^5 + c \cdot t^n.$$

Insertion into the left hand side of the differential equation gives

$$\begin{aligned} t \frac{dx}{dt} - 2x &= t \{5a t^4 + c \cdot n t^{n-1}\} - 2 \{a t^5 + c t^n\} \\ &= 3a t^5 + c \cdot (n - 2) t^n. \end{aligned}$$

This expression is equal to  $t^5$ , when  $a = \frac{1}{3}$ ,  $n = 2$  and  $c$  is arbitrary. Therefore,

$$x = \frac{1}{3} t^5 + c \cdot t^2, \quad c \in \mathbb{R}, \quad t < 0,$$

are solutions, and according to theorem 1.3 we have at the same time found the complete solution, because the structure of the solution is the correct one.

**C. TEST.** This was latently performed above in the **Third solution**.

**Example 3.4** *Find the complete solution of the differential equation*

$$\frac{dx}{dt} - \frac{2}{t} x = 2t + 5, \quad t > 0.$$

**A.** A linear inhomogeneous differential equation of first order. We shall not in this solution exploit that the left hand side by a multiplication by  $t$  formally can be put in the same form as the left hand side of the differential equation of Example 3.3. We leave it to the reader to use this shortcut.

**D.** Here we have several possibilities of solution:

- 1) Solve the equation by applying theorem 1.2.
- 2) Divide by  $t^2$  and rewrite the problem as a problem of integration.

**I. First solution.** *Application of theorem 1.2.*

Since

$$p(t) = -\frac{2}{t}, \quad q(t) = 2t + 5, \quad P(t) = -\int \frac{2}{t} dt = -2 \ln |t| = -\ln(t^2),$$

we obtain the complete solution by the solution formula given in theorem 1.2,

$$\begin{aligned} x &= e^{-P(t)} \left\{ \int e^{P(t)} q(t) dt + c \right\} = t^2 \left\{ \int \frac{1}{t^2} (2t + 5) dt + c \right\} \\ &= t^2 \left\{ \int \frac{2}{t} dt + \int \frac{5}{t^2} dt + c \right\} = t^2 \left\{ 2 \ln t - \frac{5}{t} + c \right\} \\ &= 2t^2 \ln t - 5t + c \cdot t^2, \end{aligned}$$

i.e.

$$x = 2t^2 \ln t - 5t + c \cdot t^2, \quad c \in \mathbb{R}, \quad t > 0.$$

**Second solution.** *Nice reformulations.*

By division by  $t^2 \neq 0$  for  $t > 0$  we get

$$\frac{2}{t} + \frac{5}{t^2} = \frac{1}{t^2} \frac{dx}{dt} - \frac{2}{t^3} x = \frac{1}{t^2} \frac{dx}{dt} + \frac{d}{dt} \left( \frac{1}{t^2} \right) \cdot x = \frac{d}{dt} \left( \frac{x}{t^2} \right).$$

Then by an integration,

$$\frac{x}{t^2} = \int \frac{2}{t} dt + \int \frac{5}{t^2} dt + c = 2 \ln t - \frac{5}{t} + c.$$

The complete solution is

$$x = 2t^2 \ln t - 5t + c \cdot t^2, \quad c \in \mathbb{R}, \quad t > 0.$$

**C. TEST.** When  $x = 2t^2 \ln t - 5t + ct^2$  is put into the left hand side of the differential equation we get

$$\frac{dx}{dt} - \frac{2}{t} x = 4t \ln t + 2t - 5 + 2ct - 4t \ln t + 10 - 2ct = 2t + 5.$$

We have checked our solution.

**Example 3.5** Find a polynomial of degree 1 which is a solution of the differential equation

$$\frac{dx}{dt} + t^2 x = t^3 + 1, \quad t \in \mathbb{R}.$$

Then find the complete solution of the equation.

**A.** A linear inhomogeneous differential equation of first order.

One is here *invited* to *guess* a particular solution.

**D.** Use the hint of guessing a particular solution.

Find a solution of the corresponding homogeneous equation and then apply theorem 1.3.

**I.** When  $x = at + b$  is put into the left hand side of the equation we get

$$\frac{dx}{dt} + t^2 x = at^3 + bt^2 + a.$$

This expression is equal to  $t^3 + 1$ , when  $a = 1$  and  $b = 0$ . Thus a particular solution is

$$x = t.$$

Since  $p(t) = t^2$ , we get

$$e^{-P(t)} = \exp \left( -\frac{1}{3} t^3 \right)$$

as a generating solution of the complete solution of the homogeneous equation.

Using theorem 1.3 we conclude that the complete solution is

$$x = t + c \cdot \exp \left( -\frac{1}{3} t^3 \right), \quad c \in \mathbb{R}, \quad t \in \mathbb{R}.$$

C. TEST. When  $x = t + c \cdot \exp\left(-\frac{1}{3}t^3\right)$ , we get by insertion into the left hand side of the differential equation that

$$\frac{dx}{dt} + t^2x = 1 - ct^2 \exp\left(-\frac{1}{3}t^3\right) + t^3 + ct^2 \exp\left(-\frac{1}{3}t^3\right) = t^3 + 1.$$

We have checked our solution.

Please click the advert



**DIVERSE - INNOVATIVE - INTERNATIONAL**

**Are you considering a European business degree?**

Copenhagen Business School is one of the largest business schools in Northern Europe with more than 15,000 students from Europe, North America, Australia and Asia.

Are you curious to know how a modern European business school competes with a diverse, innovative and international study environment?

Please visit Copenhagen Business School at [www.cbs.dk](http://www.cbs.dk)

**Copenhagen Business School**  
HANDELSHØJSKOLEN

Diversity creating knowledge

**P I M**  
Partnership to International Management

Accredited by  
**Association of MBAs**

EFMD  
**EQUIS**  
ACCREDITED

MEMBER OF  
**CEMS**

Download free books at [BookBooN.com](http://BookBooN.com)

**Example 3.6** Given the differential equation

$$\frac{dx}{dt} + x = \cos t, \quad t \in \mathbb{R}.$$

- 1) Does the differential equation have a solution of the form  $x = a \cos t$ ?
- 2) Does the differential equation have a solution of the form  $x = a \cos t + b \sin t$ ?
- 3) Find the complete solution of the equation.

**A.** A linear inhomogeneous differential equation of first order. One is implicitly requested to guess a particular solution followed by at determination of the complete solution.

**D.** Insert the given functions into the left hand side of the differential equation and analyze the results. ALTERNATIVELY one may use the solution formula.

**I.** 1) By insertion of  $x = a \cos t$  into the left hand side of the differential equation we get

$$\frac{dx}{dt} + x = -a \sin t + a \cos t.$$

If this expression should be equal to  $\cos t$ , we necessarily must have that both  $a = 0$  and  $a = 1$ , which is not possible. Therefore, we cannot have a solution of the suggested structure  $a \cos t$ .

2) By insertion of  $x = a \cos t + b \sin t$  into the left hand side of the differential equation we get

$$\begin{aligned} \frac{dx}{dt} + x &= -a \sin t + b \cos t + a \cos t + b \sin t \\ &= (-a + b) \sin t + (a + b) \cos t, \end{aligned}$$

which is equal to  $\cos t$  for  $a = b = \frac{1}{2}$ . Therefore, a particular solution is given by

$$x = \frac{1}{2}(\cos t + \sin t) \quad \left[ = \frac{1}{\sqrt{2}} \sin \left( t + \frac{\pi}{4} \right) \right].$$

3) We now *guess* that  $x = e^{-t}$  is a solution of the corresponding homogeneous equation. It is immediately seen that this is true.

ALTERNATIVELY we have  $p(t) = 1$ , hence  $P(t) = t$ , and thus

$$x = c \cdot e^{-P(t)} = c \cdot e^{-t}.$$

According to theorem 1.3, the complete solution is

$$x = \frac{1}{2}(\cos t + \sin t) + c \cdot e^{-t}, \quad c \in \mathbb{R}, \quad t \in \mathbb{R}.$$

ALTERNATIVELY (sketch only) we get when the equation is multiplied by  $e^t$  that

$$e^t \cos t = e^t \frac{dx}{dt} + e^t x = \frac{d}{dt} (e^t x),$$

and the solution can then be found directly by an integration.

**Example 3.7** Find the complete solution of the differential equation

$$\frac{dx}{dt} - 2tx = 2t, \quad t \in \mathbb{R}.$$

Show (without applying the Existence and Uniqueness Theorem that there to any  $(a, b) \in \mathbb{R}^2$  exists precisely one solution, the graph of which goes through  $(a, b)$ ).

Sketch the graphs of the three solutions which respectively go through the points

$$(3, -1), \quad (1, 1) \quad \text{og} \quad \left(2, -\frac{3}{2}\right).$$

**A.** A linear inhomogeneous differential equation of first order where the variables also can be separated.

Existence and uniqueness problem.

Sketches of curves.

**D.** There are several possibilities of solutions:

- 1) Application of theorem 1.2 and theorem 1.3 where one may guess a particular solution.
- 2) Multiplication by an integrating factor  $\exp(-t^2)$  followed by an integration.
- 3) Separation of the variables.

Investigate in particular the existence and the uniqueness.

Sketch the three graphs of solution.

**I. First solution.** Application of theorem 1.2 and theorem 1.3.

We first get from  $p(t) = -2t$  and  $q(t) = 2t$  that

$$P(t) = \int p(t) dt = - \int 2t dt = -t^2.$$

Thus the corresponding homogeneous equation has the complete solution

$$c \cdot \exp(-P(t)) = c \cdot \exp(t^2).$$

Then use theorem 1.2 in order to obtain a particular solution,

$$\begin{aligned} f(t) &= e^{-P(t)} \int e^{P(t)} q(t) dt = e^{t^2} \int e^{-t^2} \cdot 2t dt \\ &= e^{t^2} \int e^{-t^2} d(t^2) = -e^{t^2} \cdot e^{-t^2} = -1. \end{aligned}$$

ALTERNATIVELY it is immediately seen by *inspection* that  $x = -1$  is a solution.

According to theorem 1.3 the complete solution is then given by

$$x = -1 + c \cdot \exp(t^2), \quad c \in \mathbb{R}, \quad t \in \mathbb{R}.$$



**Second solution.** When the equation is multiplied by the *integrating factor*  $\exp(-t^2)$ , we get by the rule of differentiation of a product that

$$\begin{aligned} 2t e^{-t^2} &= e^{-t^2} \frac{dx}{dt} - 2t e^{-t^2} x \\ &= e^{-t^2} \frac{dx}{dt} + \frac{d}{dt} (e^{-t^2}) \cdot x = \frac{d}{dt} (x e^{-t^2}). \end{aligned}$$

Then by an integration,

$$x e^{-t^2} = \int 2t e^{-t^2} dt + c = -e^{-t^2} + c,$$

hence by a multiplication by  $e^{t^2} \neq 0$ ,

$$x = -1 + c \cdot e^{t^2}, \quad c \in \mathbb{R}, \quad t \in \mathbb{R}.$$

**Third solution.** *Separation of the variables.*

It follows from

$$\frac{dx}{dt} = 2tx + 2t = 2t(x + 1)$$

that the variables can be separated. Then it follows immediately that  $x = -1$  is a solution. When  $x \neq -1$  we can divide the equation by  $x + 1$ , whence

$$\frac{1}{x+1} \frac{dx}{dt} = \frac{d}{dt} \ln |x+1| = 2t.$$

Then an integration gives

$$\ln |x+1| = t^2 + k, \quad k \in \mathbb{R},$$

i.e.  $|x+1| = e^k e^{t^2}$ ,  $k \in \mathbb{R}$ . Then note that the sign of  $x+1$  can be built into the constant  $c = \pm e^k$ , and that  $c = 0$  corresponds to the solution  $x = -1$ , so we conclude that the complete solution is

$$x = -1 + c e^{t^2}, \quad c \in \mathbb{R}, \quad t \in \mathbb{R}.$$

**C.** Putting  $x = -1 + c e^{t^2}$ , we get

$$\frac{dx}{dt} - 2tx = 2txe^{t^2} + 2t - 2tce^{t^2} = 2t,$$

and we have checked our solution.

**I.** Let us now turn to the question of existence and uniqueness. We shall then get a new series of (local) **A.**, **D.**, and **I.** (first analysis, then choice of method of solution, and finally the implementation of the solution):

**I A.** Let  $x = -1 + c \cdot e^{t^2}$ ,  $c \in \mathbb{R}$ ,  $t \in \mathbb{R}$ . The task is to show that there to any  $(t, x) = (a, b)$  exists *precisely one*  $c \in \mathbb{R}$ , such that  $b = -1 + c \cdot e^{a^2}$ .

**I D.** Solve the equation  $b = -1 + c \cdot e^{a^2}$  with respect to  $c$  for given  $(a, b)$ .

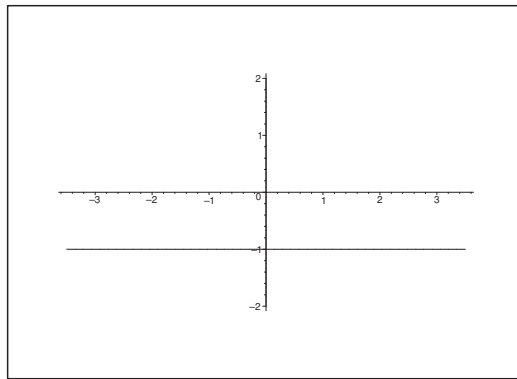

Figure 19: The solution curve  $x = -1$  through  $(3, -1)$ .

I I. From  $b = -1 + c \cdot e^{a^2}$  we get

$$c = e^{-a^2}(b + 1),$$

which shows that the solution  $c$  exists and is uniquely determined.

I. Sketches of curves for  $x = -1 + c \cdot e^{t^2}$  through chosen points.

1) When  $(a, b) = (3, -1)$ , it follows from the above that

$$c = e^{-a^2}(b + 1) = e^{-9}(-1 + 1) = 0.$$

Hence the solution is  $x = -1$ .

Please click the advert



## Sharp Minds - Bright Ideas!

Employees at FOSS Analytical A/S are living proof of the company value - First - using new inventions to make dedicated solutions for our customers. With sharp minds and cross functional teamwork, we constantly strive to develop new unique products - Would you like to join our team?

FOSS works diligently with innovation and development as basis for its growth. It is reflected in the fact that more than 200 of the 1200 employees in FOSS work with Research & Development in Scandinavia and USA. Engineers at FOSS work in production, development and marketing, within a wide range of different fields, i.e. Chemistry, Electronics, Mechanics, Software, Optics, Microbiology, Chemometrics.

**We offer**  
*A challenging job in an international and innovative company that is leading in its field. You will get the opportunity to work with the most advanced technology together with highly skilled colleagues.*

*Read more about FOSS at [www.foss.dk](http://www.foss.dk) - or go directly to our student site [www.foss.dk/sharpminds](http://www.foss.dk/sharpminds) where you can learn more about your possibilities of working together with us on projects, your thesis etc.*

The Family owned FOSS group is the world leader as supplier of dedicated, high-tech analytical solutions which measure and control the quality and production of agricultural, food, pharmaceutical and chemical products. Main activities are initiated from Denmark, Sweden and USA with headquarters domiciled in Hillerød, DK. The products are marketed globally by 23 sales companies and an extensive net of distributors. In line with the corevalue to be 'First', the company intends to expand its market position.





Dedicated Analytical Solutions

FOSS  
 Slangerupgade 69  
 3400 Hillerød  
 Tel. +45 70103370  
[www.foss.dk](http://www.foss.dk)

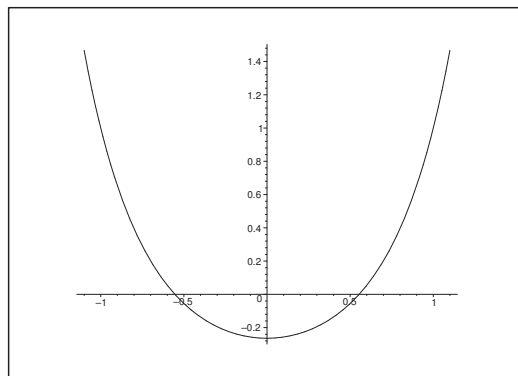

Figure 20: The solution curve  $x = -1 + 2e^{t^2-1}$  through  $(1, 1)$ .

2) When  $(a, b) = (1, 1)$ , we get

$$c = e^{-1}(1 + 1) = \frac{2}{e}.$$

The solution is

$$x = -1 + \frac{2}{e} \cdot e^{t^2}.$$

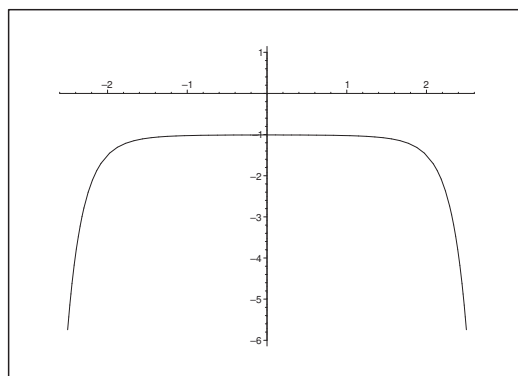

Figure 21: The solution curve  $x = -1 - \frac{1}{2}e^{t^2-4}$  through  $\left(2, -\frac{3}{2}\right)$ .

3) When  $(a, b) = \left(2, -\frac{3}{2}\right)$ , we get

$$c = e^{-4} \left( -\frac{3}{2} + 1 \right) = -\frac{e^{-4}}{2}.$$

The solution is

$$x = -1 - \frac{1}{2}e^{t^2-4}.$$

**Example 3.8** Find the complete solution of the differential equation

$$\frac{dx}{dt} - \frac{1}{t}x = \frac{1}{t+1} \sqrt{\frac{t-1}{t+1}}, \quad t > 1.$$

- A.** A normed linear inhomogeneous differential equation of first order.  
**D.** Either multiply by the integrating factor  $1/t$  and then reduce, or apply the solution formula. By the integration we shall use some substitution.  
**I.** First note that both the left hand side and the right hand side are defined for  $t > 1$ . When we divide the equation by  $t > 1$ , we get

$$\frac{1}{t(t+1)} \sqrt{\frac{t-1}{t+1}} = \frac{1}{t} \frac{dx}{dt} - \frac{1}{t^2}x = \frac{1}{t} \frac{dx}{dt} + \frac{d}{dt} \left( \frac{1}{t} \right) \cdot x = \frac{d}{dt} \left( \frac{x}{t} \right),$$

hence by an integration and a multiplication by  $t > 1$ ,

$$x = t \int \frac{1}{t(t+1)} \sqrt{\frac{t-1}{t+1}} dt + ct.$$

We calculate this integral by using the monotonous substitution

$$u = \sqrt{\frac{t-1}{t+1}} \in ]0, 1[, \quad \text{i.e.} \quad \frac{t-1}{t+1} = u^2,$$

hence

$$t = \frac{1+u^2}{1-u^2} = \frac{2}{1-u^2} - 1 \quad \text{og} \quad dt = \frac{4u}{(1-u^2)^2} du.$$

**REMARK.** The technique of applying the method of substitution is best explained by giving some “nasty expression” a short name. In this particular case one would consider the square root of a fractional function of the variable as fairly “ugly”, so why not call this the new variable  $u$ ?  $\diamond$ .

Applying this substitution we get the integral

$$\begin{aligned} \int \frac{1}{t(t+1)} \sqrt{\frac{t-1}{t+1}} dt &= \int \frac{1-u^2}{1+u^2} \cdot \frac{1}{\frac{1+u^2}{1-u^2} + 1} \cdot u \cdot \frac{4u}{(1-u^2)^2} du, \quad u = \sqrt{\frac{t-1}{t+1}} \\ &= \int \frac{1-u^2}{1+u^2} \cdot \frac{1-u^2}{2} \cdot \frac{4u^2}{(1-u^2)^2} du = \int \frac{2u^2}{1+u^2} du, \quad u = \sqrt{\frac{t-1}{t+1}} \\ &= 2 \int \left( 1 - \frac{1}{1+u^2} \right) du = 2u - 2 \operatorname{Arctan} u, \quad u = \sqrt{\frac{t-1}{t+1}} \\ &= 2\sqrt{\frac{t-1}{t+1}} - 2 \operatorname{Arctan} \left( \sqrt{\frac{t-1}{t+1}} \right). \end{aligned}$$

The complete solution is then

$$x = 2t \sqrt{\frac{t-1}{t+1}} - 2t \operatorname{Arctan} \left( \sqrt{\frac{t-1}{t+1}} \right) + ct, \quad t > 1, \quad c \in \mathbb{R}.$$

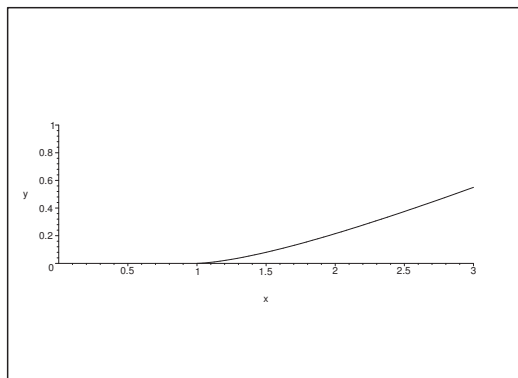
Figure 22: The solution curve for  $c = 0$ .

C. TEST. We first calculate

$$\begin{aligned} \frac{dx}{dt} &= 2\sqrt{\frac{t-1}{t+1}} + 2t \cdot \frac{1}{2} \sqrt{\frac{t+1}{t-1}} \cdot \frac{t+1-(t-1)}{(t+1)^2} - 2 \operatorname{Arctan} \left( \sqrt{\frac{t-1}{t+1}} \right) \\ &\quad - 2t \cdot \frac{1}{1 + \frac{t-1}{t+1}} \cdot \sqrt{\frac{t+1}{t-1}} \cdot \frac{1}{(t+1)^2} + c, \end{aligned}$$

from which

$$\begin{aligned} \frac{dx}{dt} - \frac{1}{t}x &= 2\sqrt{\frac{t-1}{t+1}} + 2t\sqrt{\frac{t+1}{t-1}} \cdot \frac{1}{(t+1)^2} - 2 \operatorname{Arctan} \left( \sqrt{\frac{t-1}{t+1}} \right) + c \\ &\quad - \frac{2t(t+1)}{2t} \sqrt{\frac{t+1}{t-1}} \cdot \frac{1}{(t+1)^2} - 2\sqrt{\frac{t-1}{t+1}} \\ &\quad + 2 \operatorname{Arctan} \left( \sqrt{\frac{t-1}{t+1}} \right) - c \\ &= 2t\sqrt{\frac{t+1}{t-1}} \cdot \frac{1}{(t+1)^2} - (t+1)\sqrt{\frac{t+1}{t-1}} \cdot \frac{1}{(t+1)^2} \\ &= \frac{t-1}{(t+1)^2} \sqrt{\frac{t+1}{t-1}} = \frac{1}{t+1} \sqrt{\frac{t-1}{t+1}}, \end{aligned}$$

and we have checked our solution.

**Example 3.9** We assume that a solution  $x_0(t)$  of the differential equation

$$\frac{dx}{dt} + 2x = a$$

satisfies  $x(0) = 3$  and  $x(t) \rightarrow 7$  for  $t \rightarrow \infty$ . Find  $x_0(t)$ .

- A. A linear inhomogeneous differential equation of first order with an unknown constant  $a$  and two conditions.
- D. Multiply by the integrating factor  $e^{2t}$  before the integration, or use the standard method. Then find the constants  $a$  and  $c$  by means of the given conditions.

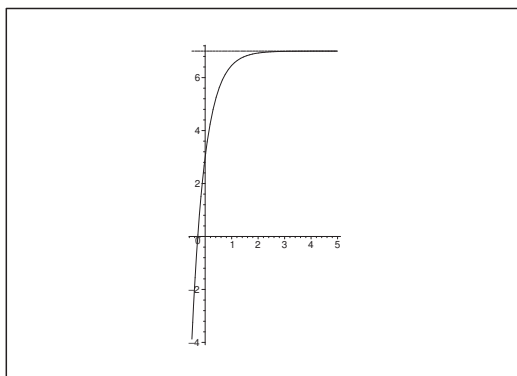

Figure 23: The solution  $x_0(t) = 7 - 4e^{-2t}$ .

**I. First solution.** By a multiplication by the integrating factor  $e^{2t}$  followed by a rearrangement we get

$$ae^{2t} = e^{2t} \frac{dx}{dt} + 2e^{2t}x = e^{2t} \cdot \frac{dx}{dt} + \frac{d}{dt}(e^{2t}) \cdot x = \frac{d}{dt}(e^{2t} \cdot x).$$

Then by an integration,

$$e^{2t} \cdot x(t) = \frac{1}{2}ae^{2t} + c,$$

and we get the complete solution

$$x(t) = \frac{1}{2}a + c \cdot e^{-2t}, \quad t \in \mathbb{R}, \quad c \in \mathbb{R}.$$

**Second solution.** By an application of the solution formula and some unconscious calculations we get

$$\begin{aligned} x(t) &= c \cdot \exp\left(-\int 2 dt\right) + \exp\left(-\int 2 dt\right) \cdot \left\{ \int \exp\left(\int 2 dt\right) \cdot a dt \right\} \\ &= c \cdot e^{-2t} + e^{-2t} \int e^{2t} \cdot a dt = \frac{1}{2}a + c \cdot e^{-2t}, \end{aligned}$$

which of course is the same result as in the first solution.

By insertion in the conditions we obtain the equations

$$x(0) = \frac{1}{2}a + c = 3,$$

and

$$\lim_{t \rightarrow \infty} x(t) = \lim_{t \rightarrow \infty} \left\{ \frac{1}{2}a + c \cdot e^{-2t} \right\} = \frac{1}{2}a = 7,$$

from which we get that  $a = 14$  and  $c = -4$ .

We conclude that the solution is

$$x_0(t) = 7 - 4e^{-2t}.$$

**Example 3.10** Consider the differential equation

$$(6) \quad \frac{dx}{dt} - 2tx = 2t^3 - 2t^2 + 1, \quad t \in \mathbb{R}.$$

- 1) Find a solution of (6) by guessing a polynomial.
- 2) Find the complete solution of (6).

**A.** A linear differential equation of first order. Find the complete solution.

- D.** 1) Check if a polynomial (it suffices by degree 2) is a solution.  
2) Apply theorem 1.2 and theorem 1.3.

- I.** 1) Since  $\frac{dx}{dt}$  decreases the degree of a polynomial and multiplication by  $t$  increases the degree by 1 it suffices to guess  $x = at^2 + bt + c$ . When this is inserted in (6) we get

$$\begin{aligned} \frac{dx}{dt} - 2tx &= 2at + b - 2at^3 - 2bt^2 - 2ct \\ &= -2at^3 - 2bt^2 + 2(a - c)t + b. \end{aligned}$$

Choosing  $a = -1$  and  $b = -1$  and  $c = a = -1$ , we get

$$\frac{dx}{dt} - 2tx = 2t^3 - 2t^2 + 0 \cdot t + 1 = 2t^3 - 2t^2 + 1,$$

and we have found a particular solution

$$x = -t^2 + t - 1, \quad t \in \mathbb{R}.$$

- 2) It is seen by inspection that the complete solution of the corresponding homogeneous equation is

$$x = c \cdot \exp(t^2), \quad c \in \mathbb{R}, \quad t \in \mathbb{R}.$$

Then it follows from theorem 1.3 that the complete solution of the inhomogeneous equation is

$$x = -t^2 + t - 1 + c \cdot \exp(t^2), \quad c \in \mathbb{R}, \quad t \in \mathbb{R}.$$

C. Putting  $x = -t^2 + t - 1 + c \cdot \exp(t^2)$  we get

$$\begin{aligned} \frac{dx}{dt} - 2tx &= -2t + 1 + 2ct \exp(t^2) + 2t^3 - 2t^2 + 2t - 2ct \exp(t^2) \\ &= 2t^3 - 2t^2 + 1, \end{aligned}$$

and we have checked our solution.

**Example 3.11** 1) Find the complete solution of the differential equation

$$(7) \quad \frac{dx}{dt} + \left(2t - \frac{1}{t}\right)x = 2t^2, \quad t > 0.$$

2) Find the solution  $\varphi(t)$  of (7), for which

$$\lim_{t \rightarrow 0^+} \varphi'(t) = 0.$$

A. A linear inhomogeneous differential equation of first order.

D. Apply the solution formula. Then insert the condition in the complete solution in order to get the constant  $c$ .

Please click the advert







[www.1calendar.dk](http://www.1calendar.dk)



I. 1) From

$$P(t) = \int \left( 2t - \frac{1}{t} \right) dt = t^2 - \ln t,$$

we get the complete solution

$$\begin{aligned} x(t) &= c \cdot e^{-P(t)} + e^{-P(t)} \int e^{P(t)} q(t) dt \\ &= c \cdot t e^{-t^2} + t e^{-t^2} \int \frac{1}{t} e^{t^2} \cdot 2t^2 dt \\ &= t + c \cdot t e^{-t^2}. \end{aligned}$$

2) Since

$$\frac{dx}{dt} = \varphi'(t) = 1 + c \cdot e^{-t^2} - 2ct^2 e^{-t^2} \rightarrow 1 + c \quad \text{for } t \rightarrow 0+,$$

we get  $c = -1$ , hence

$$\varphi(t) = t - t e^{-t^2} = t \left( 1 - e^{-t^2} \right).$$

C. TEST. It follows immediately from

$$\varphi'(t) = 1 - e^{-t^2} + 2t^2 e^{-t^2},$$

that

$$\lim_{t \rightarrow 0+} \varphi'(t) = 1 - 1 + 0 = 0.$$

By insertion in the differential equation for  $t > 0$  we get

$$\varphi'(t) + \left( 2t - \frac{1}{t} \right) \varphi(t) = 1 - e^{-t^2} + 2t^2 e^{-t^2} + 2t^2 - 2t^2 e^{-2t^2} - 1 + e^{-t^2} = 2t^2,$$

and we have checked our solution.

**Example 3.12** Find the complete solution of the differential equation

$$\frac{dx}{dt} + \frac{2}{1-t^2} x = 1 - t, \quad |t| < 1.$$

A. A linear inhomogeneous differential equation of first order.

D. Apply the solution formula.

I. From

$$P(t) = \int \frac{2}{1-t^2} dt = \int \left\{ \frac{1}{1-t} + \frac{1}{1+t} \right\} dt = \ln \left| \frac{1+t}{1-t} \right| = \ln \left( \frac{1+t}{1-t} \right),$$

follows that the complete solution for  $|t| < 1$  is given by

$$\begin{aligned} x &= c \cdot \frac{1-t}{1+t} + \frac{1-t}{1+t} \int \frac{1+t}{1-t} \cdot (1-t) dt \\ &= c \cdot \frac{1-t}{1+t} + \frac{1-t}{1+t} \cdot \frac{1}{2} (1+t)^2 \\ &= \frac{1}{2} (1-t^2) + c \cdot \frac{1-t}{1+t}, \quad t \in ]-1, 1[. \end{aligned}$$

**Example 3.13** Find the solution  $x = \varphi(t)$  of the differential equation

$$\frac{dx}{dt} + 3t^2x = t^2, \quad t \in \mathbb{R},$$

for which  $\varphi(0) = 1$ .

- A. A linear inhomogeneous differential equation of first order.  
 D. Apply the solution formula.

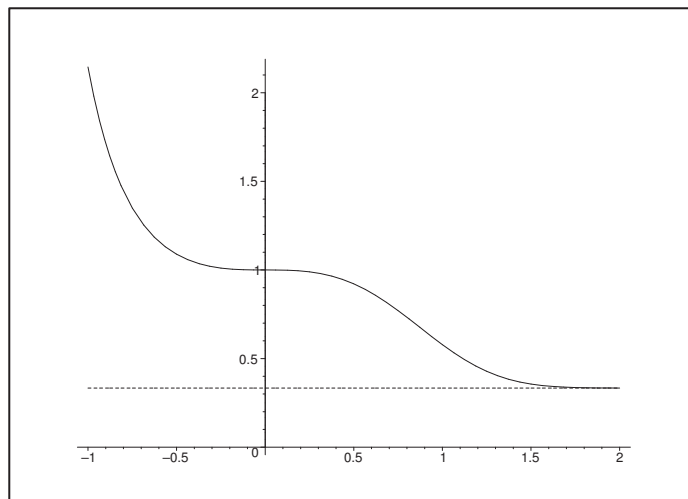

Figure 24: The graph of the solution  $\varphi(t) = \frac{1}{3} \{1 + 2e^{-t^3}\}$  with its asymptote  $x = \frac{1}{3}$ .

I. From  $P(t) = \int 3t^2 dt = t^3$  follows that the complete solution is

$$x = c \cdot e^{-t^3} + e^{-t^3} \int t^2 \cdot e^{t^3} dt = \frac{1}{3} + c \cdot e^{-t^3},$$

where

$$x(0) = \frac{1}{3} + c = 1, \quad \text{dvs. } c = \frac{2}{3}.$$

Then the wanted particular solution is

$$x = \varphi(t) = \frac{1}{3} \left\{ 1 + 2e^{-t^3} \right\}, \quad t \in \mathbb{R}.$$

**Example 3.14** Find the complete solution of the differential equation

$$\frac{dx}{dt} - \frac{\cos t}{\sin t} x = \sin t, \quad t \in ]0, \pi[.$$

**A.** A linear inhomogeneous differential equation of first order.

**D.** Apply the solution formula.

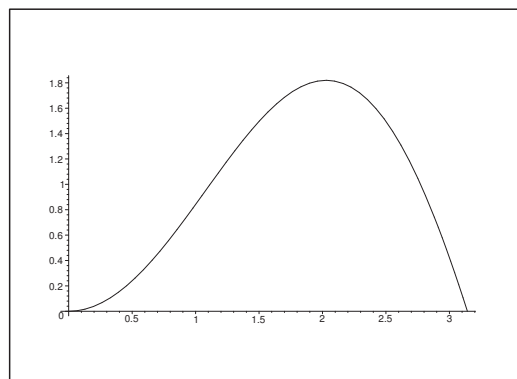

Figure 25: The graph of the particular solution  $x_0(t) = t \cdot \sin t$ .

**I.** From

$$P(t) = - \int \frac{\cos t}{\sin t} dt = - \int \frac{d \sin t}{\sin t} = - \ln |\sin t| = - \ln \sin t,$$

follows that the complete solution is

$$\begin{aligned} x(t) &= c \cdot \sin t + \sin t \int \frac{1}{\sin t} \cdot \sin t dt \\ &= t \cdot \sin t + c \cdot \sin t. \end{aligned}$$

**Example 3.15** Find the complete solution of the differential equation

$$\frac{dx}{dt} - \frac{1}{t}x = 1, \quad t > 0.$$

**A.** A linear inhomogeneous differential equation of first order.

**D.** Here we have several variants of solutions.

**I. First variant.** *Solution formula.* From

$$P(t) = - \int \frac{1}{t} dt = - \ln t, \quad t > 0,$$

follows that the complete solution is

$$x = c \cdot t + t \int \frac{1}{t} \cdot 1 dt = t \cdot \ln t + c \cdot t, \quad t > 0, \quad c \in \mathbb{R}.$$

**Second variant.** *Integrating factor.* When we divide the equation by  $t > 0$  we get

$$\frac{1}{t} = \frac{1}{t} \frac{dx}{dt} - \frac{1}{t^2}x = \frac{1}{t} \cdot \frac{dx}{dt} + \frac{d}{dt} \left( \frac{1}{t} \right) \cdot x = \frac{d}{dt} \left( \frac{x}{t} \right),$$

Please click the advert

**Design your  
own future at  
MAN Diesel**

[www.mandiesel.com](http://www.mandiesel.com)

**MAN Diesel** – Powering the World



Download free books at [BookBooN.com](http://BookBooN.com)

hence by an integration,

$$\frac{x}{t} = c + \ln t,$$

and the complete solution is

$$x = t \cdot \ln t + c \cdot t, \quad t > 0, \quad c \in \mathbb{R}.$$

**Third variant.** *Euler differential equation.* When we multiply the equation by  $t > 0$  we obtain an inhomogeneous *Euler differential equation*,

$$t \frac{dx}{dt} - x = t.$$

REMARK. The characterization of an *Euler differential equation* is that any  $j$ -th derivative of  $x$  is multiplied by a constant times  $t^j$ .  $\diamond$

The trick used on this type of equation is to *guess* a solution of the form  $x = t^n$  and then solve with respect to  $n$ . In the present case we get

$$t \frac{dx}{dt} - x = t \cdot n t^{n-1} - t^n = (n-1)t^n,$$

since the structure of an Euler differential equation secures that the result becomes a constant times  $t^n$ .

It follows that for  $n = 1$  we get a solution of the homogeneous equation,  $c \cdot t$ .

Now the right hand side has the same form as a solution of the homogeneous equation. For Euler equations the trick is to multiply by  $\ln t$ , i.e. one guesses that a solution is  $x = c \cdot t \cdot \ln t$ . We get by insertion

$$\frac{dx}{dt} - \frac{1}{t} x = c \cdot \ln t + c - c \cdot \ln t = c = 1.$$

It is seen that we get a particular solution for  $c = 1$ , and then we conclude from theorem 1.3 that the complete solution is given by

$$x = t \cdot \ln t + c \cdot t, \quad t > 0, \quad c \in \mathbb{R}.$$

**Example 3.16** Find the complete solution of the differential equation

$$\frac{dx}{dt} + \left(1 + \frac{1}{t}\right)x = \frac{1}{t}, \quad t > 0.$$

**A.** A linear inhomogeneous differential equation of first order.

**D.** Apply the solution formula.

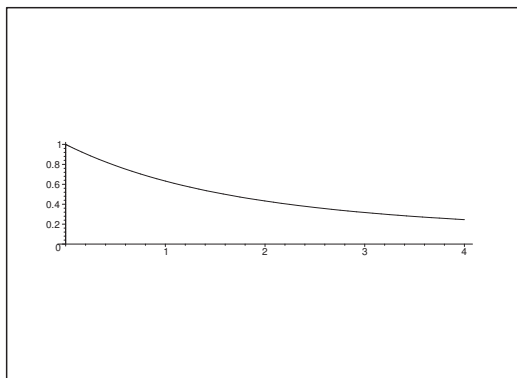

Figure 26: The graph of the only bounded solution  $\frac{1}{t} - \frac{1}{t \cdot e^t}$ ,  $t > 0$  for  $c = -1$ .

I. From  $p(t) = 1 + \frac{1}{t}$  follows that  $P(t) = \int \left(1 + \frac{1}{t}\right) dt = t + \ln t$ , hence the complete solution is for  $t > 0$

$$\begin{aligned} x &= \frac{c}{t \cdot e^t} + \frac{1}{t \cdot e^t} \int t \cdot e^t \cdot \frac{1}{t} dt \\ &= \frac{1}{t} + \frac{c}{t \cdot e^t}, \quad t > 0, \quad c \in \mathbb{R}. \end{aligned}$$

The solution is bounded for  $c = -1$ . On the other hand, when  $c \neq -1$  the solution is unbounded for  $t \rightarrow 0+$ .

**Example 3.17** Find the complete solution of the differential equation

$$\frac{dx}{dt} + (1 + \tan t)x = \cos t, \quad t \in \left] -\frac{\pi}{2}, \frac{\pi}{2} \right[.$$

A. A linear inhomogeneous differential equation of first order.

D. Apply the solution formula.

I. From  $p(t) = 1 + \tan t = 1 + \frac{\sin t}{\cos t}$  follows that

$$P(t) = \int \left\{ 1 + \frac{\sin t}{\cos t} \right\} dt = t - \ln |\cos t|, \quad t \in \left] -\frac{\pi}{2}, \frac{\pi}{2} \right[.$$

The complete solution is then

$$\begin{aligned} x &= c \cdot e^{-P(t)} + e^{-P(t)} \int e^{P(t)} \cdot \cos t dt \\ &= c \cdot e^{-t} \cos t + e^{-t} \cos t \int \frac{e^t}{\cos t} \cdot \cos t dt \\ &= \cos t + c \cdot e^{-t} \cos t, \quad t \in \left] -\frac{\pi}{2}, \frac{\pi}{2} \right[, \quad c \in \mathbb{R}. \end{aligned}$$

**Example 3.18** Find the complete solution of the differential equation

$$\frac{dx}{dt} + \frac{2t}{1+t^2}x = 1, \quad t \in \mathbb{R}.$$

**A.** A linear inhomogeneous differential equation of first order.

**D.** Apply the solution formula, or find an integrating factor.

**First variant.** From  $p(t) = \frac{2t}{1+t^2}$  follows that  $P(t) = \ln(1+t^2)$ , hence  $e^{-P(t)} = \frac{1}{1+t^2}$ . The complete solution is then given by

$$\begin{aligned} x &= \frac{c}{1+t^2} + \frac{1}{1+t^2} \int (1+t^2) dt \\ &= \frac{1}{3} \cdot \frac{3t+t^3}{1+t^2} + \frac{c}{1+t^2}, \quad t \in \mathbb{R}, \quad c \in \mathbb{R}. \end{aligned}$$

**Second variant.** When the equation is multiplied by the integrating factor  $1+t^2 > 0$  we get

$$\begin{aligned} 1+t^2 &= (1+t^2) \frac{dx}{dt} + 2t \cdot x \\ &= (1+t^2) \cdot \frac{dx}{dt} + \frac{d}{dt}(1+t^2) \cdot x \\ &= \frac{d}{dt} \{(1+t^2)x\}. \end{aligned}$$

Then by an integration

$$(1+t^2)x = c + t + \frac{1}{3}t^3 = c + \frac{t}{3}(3+t^2),$$

and the complete solution is

$$x = \frac{t}{3} \cdot \frac{t^2+3}{t^2+1} + \frac{c}{t^2+1}, \quad t \in \mathbb{R}, \quad c \in \mathbb{R}.$$

**Example 3.19** Find the complete solution of the differential equation

$$\frac{dx}{dt} + \frac{2t}{1+t^2}x = \frac{1}{2t^2+1}, \quad t \in \mathbb{R}.$$

**A.** A linear inhomogeneous differential equation of first order.

**D.** Either reuse Example 3.18 when the solution formula is applied, or find an integrating factor.

**I. First variant.** We get like in Example 3.18 that  $e^{-P(t)} = \frac{1}{1+t^2}$ , and the complete solution becomes

$$\begin{aligned} x &= \frac{c}{1+t^2} + \frac{1}{1+t^2} \int \frac{t^2+1}{2t^2+1} dt \\ &= \frac{c}{1+t^2} + \frac{1}{2} \cdot \frac{1}{1+t^2} \int \left\{ 1 + \frac{1}{1+(\sqrt{2}t)^2} \right\} dt \\ &= \frac{c}{1+t^2} + \frac{1}{2} \cdot \frac{1}{1+t^2} \left\{ t + \frac{1}{\sqrt{2}} \operatorname{Arctan}(\sqrt{2}t) \right\}. \end{aligned}$$

**Second variant.** When we multiply by the integrating factor  $1 + t^2$  we get

$$\frac{1+t^2}{1+2t^2} = (1+t^2) \frac{dx}{dt} + 2t \cdot x = \frac{d}{dt} \{(1+t^2)x\} = \frac{1}{2} \left\{ 1 + \frac{1}{1+(\sqrt{2})^2} \right\}.$$

Then by an integration,

$$(1+t^2)x = \frac{1}{2} \left\{ t + \frac{1}{\sqrt{2}} \operatorname{Arctan}(\sqrt{2}t) \right\} + c,$$

and the complete solution is given by

$$x = \frac{1}{2(1+t^2)} \left\{ t + \frac{1}{\sqrt{2}} \operatorname{Arctan}(\sqrt{2}t) \right\} + \frac{c}{1+t^2}, \quad t \in \mathbb{R}, \quad c \in \mathbb{R}.$$

Please click the advert

**Student Discounts** + **Student Events** + **Money Saving Advice** = **Happy Days!**

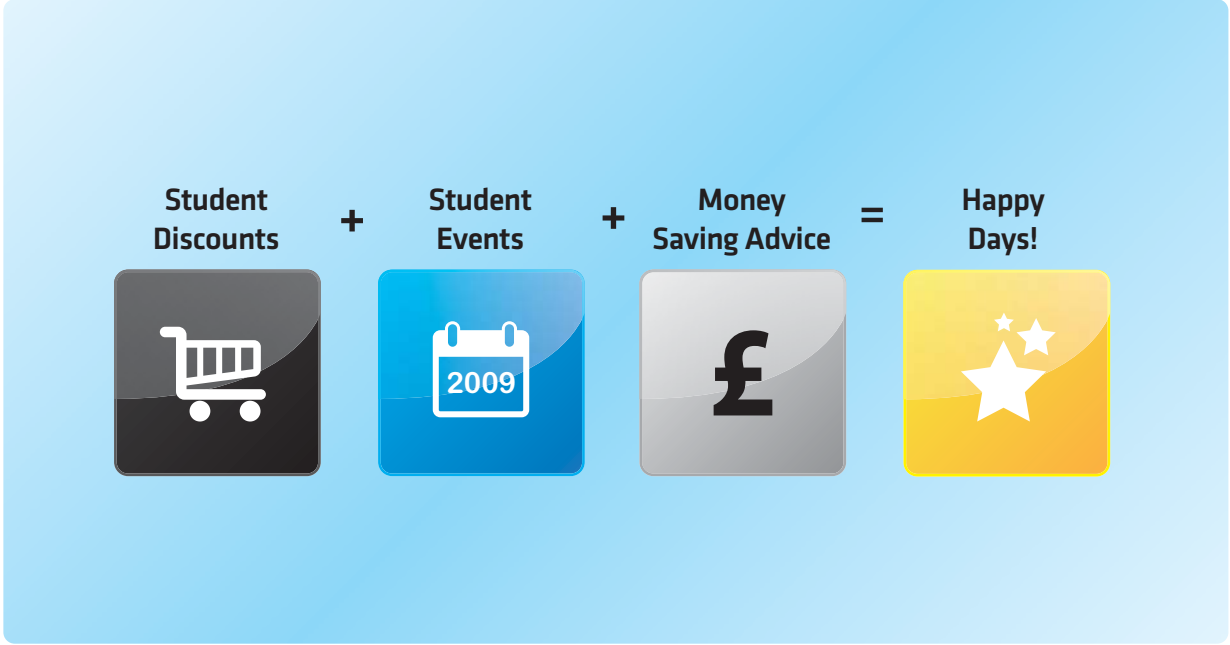

**wealthy**student.co.uk



**Example 3.20** Find the complete solution of the differential equation

$$\frac{dx}{dt} + \frac{1 + \tan^2 t}{\tan t} x = 1$$

in the interval  $]0, \frac{\pi}{2}[$ .

Does there exist a solution  $\psi(t)$  which has a (finite) limit for  $t \rightarrow 0+$ ?

**A.** A linear inhomogeneous differential equation of first order.

**D.** Apply the solution formula, or find an integrating factor.

**I. First variant.** From

$$P(t) = \int \frac{1 + \tan^2 t}{\tan t} dt = \int \frac{d \tan t}{\tan t} = \ln \tan t, \quad \text{for } t \in ]0, \frac{\pi}{2}[,$$

follows that the complete solution is

$$\begin{aligned} x &= \frac{c}{\tan t} + \frac{1}{\tan t} \int \tan t dt \\ &= c \cot t - \cot t \cdot \ln \cos t, \quad t \in ]0, \frac{\pi}{2}[, \quad c \in \mathbb{R}. \end{aligned}$$

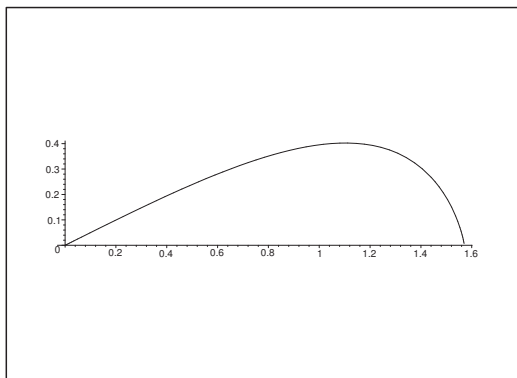

Figure 27: Graph of the solution  $\psi(t) = -\cos t \cdot \ln \cos t$ .

**Second variant.** When the equation is multiplied by the integrating factor  $\tan t$ , we get

$$\frac{\sin t}{\cos t} = \tan t = \tan t \cdot \frac{dx}{dt} + (1 + \tan^2 t) \cdot x = \frac{d}{dt} \{ \tan t \cdot x \},$$

hence by an integration,

$$\tan t \cdot x = -\ln \cos t + c,$$

and the complete solution is

$$x = -\cos t \cdot \ln \cos t + c \cdot \cot t, \quad t \in ]0, \frac{\pi}{2}[, \quad c \in \mathbb{R}.$$

Then note that it follows by e.g. l'Hospital's theorem that

$$\begin{aligned}\lim_{t \rightarrow 0^+} \{-\cot t \cdot \ln \cos t\} &= -\lim_{t \rightarrow 0^+} \left\{ \cos t \cdot \frac{\ln \cos t}{\sin t} \right\} \\ &= -1 \cdot \lim_{t \rightarrow 0^+} \frac{-\frac{\sin t}{\cos}}{\cos t} = \lim_{t \rightarrow 0^+} \frac{\sin t}{\cos^2 t} = 0.\end{aligned}$$

Since  $\cos t \rightarrow 1$  for  $t \rightarrow 0^+$ , we get  $c = 0$ . Thus the wanted solution is

$$\psi(t) = -\cos t \cdot \ln \cos t.$$

**Example 3.21** Find the complete solution of the differential equation

$$\frac{dx}{dt} - \tan(t) \cdot x = t, \quad t \in \left] -\frac{\pi}{2}, \frac{\pi}{2} \right[.$$

**A.** A linear and inhomogeneous differential equation of first order with variable coefficients.

**D.** We either multiply by  $\cos t$  and reduce, or use the solution formula.

**I. First variant.** When the equation is multiplied by  $\cos t \neq 0$  for  $t \in \left] -\frac{\pi}{2}, \frac{\pi}{2} \right[$ , we get the equivalent equation

$$t \cdot \cos t = \cos t \cdot \frac{dx}{dt} - \sin t \cdot x = \frac{d}{dt} \{ \cos t \cdot x \},$$

from which

$$\cos t \cdot x = \int t \cdot \cos t \, dt = t \cdot \sin t + \cos t + c,$$

hence

$$x = 1 + t \cdot \tan t + \frac{c}{\cos t}, \quad t \in \left] -\frac{\pi}{2}, \frac{\pi}{2} \right[, \quad c \in \mathbb{R}.$$

**Second variant.** Since  $p(t) = -\tan t$ , we obtain

$$-P(t) = \int \tan t \, dt = \int \frac{\sin t}{\cos t} \, dt = -\ln(\cos t), \quad t \in \left] -\frac{\pi}{2}, \frac{\pi}{2} \right[,$$

and the complete solution of the homogeneous equation is then

$$x = \frac{c}{\cos t}, \quad t \in \left] -\frac{\pi}{2}, \frac{\pi}{2} \right[, \quad c \in \mathbb{R}.$$

The complete solution of the inhomogeneous equation is given by

$$x = 1 + t \cdot \tan t + \frac{c}{\cos t}, \quad t \in \left] -\frac{\pi}{2}, \frac{\pi}{2} \right[, \quad c \in \mathbb{R}.$$

**Example 3.22** Prove that there exist no polynomial which is a solution of the differential equation

$$\frac{dx}{dt} + xt = t^2, \quad t \in \mathbb{R}.$$

Is it possible to find a solution of the differential equation by applying the known solution methods?

**A.** A linear inhomogeneous differential equation of first order.

What does the complete solution look like?

**D.** Insert a polynomial and see what happens.

Then apply theorem 1.2.

**I.** When  $x$  is a polynomial of degree  $n$  in  $t$ , then  $\frac{dx}{dt}$  is either 0 (for  $n = 0$ ) or of degree  $n - 1$ , and  $tx$  is of degree  $n + 1$ . Consequently the term  $tx$  can only be balanced by a term on the right hand side  $t^2$ , when the polynomial  $x$  is of first degree. We therefore put

$$x = at + b$$

into the left hand side of the differential equation. Then

$$\frac{dx}{dt} + xt = a + at^2 + bt = a(t^2 + 1) + bt.$$

By setting the coefficients of  $t^2$ , resp.  $t$ , equal to each other we get  $a = 1$  and  $b = 0$ . Unfortunately the test

$$\frac{dx}{dt} + xt = t^2 + 1 \neq t^2$$

shows that this expression is never equal to  $t^2$ .

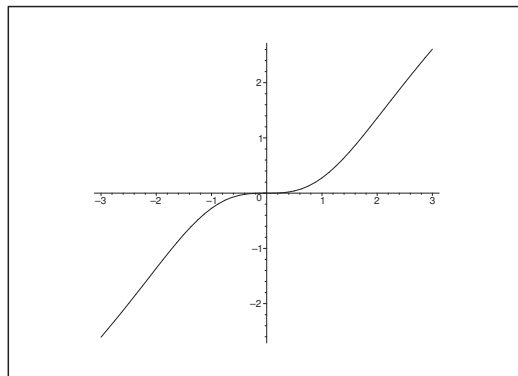

Figure 28: The graph of  $f(t) = \exp\left(-\frac{t^2}{2}\right) \int_0^t \exp\left(\frac{s^2}{2}\right) s^2 ds$ .

It follows from  $p(t) = t$  and  $q(t) = t^2$  that  $P(t) = \frac{1}{2}t^2$  and

$$x = \exp\left(-\frac{1}{2}t^2\right) \left\{ \int \exp\left(\frac{1}{2}t^2\right) t^2 dt + c \right\}$$

where we have applied theorem 1.2.

The problem here is that even if we have a solution formula, we cannot calculate the integral

$$\begin{aligned} \int \exp\left(\frac{1}{2}t^2\right) t^2 dt &= \int \left(t \exp\left(\frac{1}{2}t^2\right)\right) t dt \\ &= t \exp\left(\frac{1}{2}t^2\right) - \int \exp\left(\frac{1}{2}t^2\right) dt \end{aligned}$$

with the functions we know at this stage, so we cannot calculate the integral explicitly. Instead we may use programmes like MAPLE. For example the figure has been made by use of MAPLE.

Please click the advert

## WHAT'S MISSING IN THIS EQUATION?

You could be one of our future talents

### MAERSK INTERNATIONAL TECHNOLOGY & SCIENCE PROGRAMME

Are you about to graduate as an **engineer** or **geoscientist**? Or have you already graduated?  
If so, there may be an exciting future for you with A.P. Moller - Maersk.



**MAERSK**

[www.maersk.com/mitas](http://www.maersk.com/mitas)

Download free books at [BookBooN.com](http://BookBooN.com)

## 4 The Existence and Uniqueness Theorem and other theoretical considerations

**Example 4.1** Let the function  $h(t)$  be given by

$$h(t) = \begin{cases} (t-1)^2, & t \geq 1, \\ 0, & t < 1, \end{cases}$$

Sketch the graph of  $h(t)$ . Prove that  $h(t)$  is differentiable for every  $t \in \mathbb{R}$ . Show that  $h(t)$  is a solution of the differential equation

$$\frac{dx}{dt} = 2\sqrt{x}, \quad x \geq 0, \quad t \in \mathbb{R}.$$

The functions  $x = h(t)$  and  $x = 0$  are both solutions of the differential equation, and they both take on the value 0 for  $t = 1$ . Why is this not a contradiction to the *Existence and Uniqueness Theorem*?

**A.** We shall prove that a differential equation may have two different solutions going through the same point without violating the *Existence and Uniqueness Theorem*.

**D.** Check the differentiability of  $h(t)$ .

Check the differential equation.

Read the *Existence and Uniqueness Theorem* thoroughly and analyze the given equation!

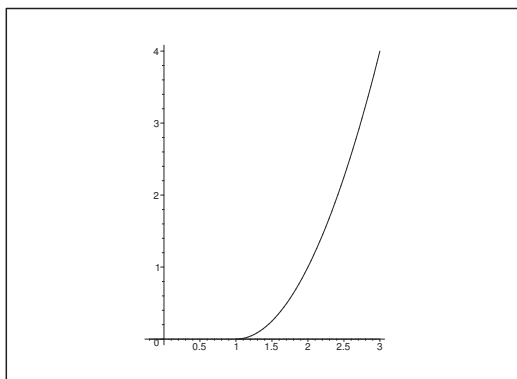

Figure 29: The graph of  $h(t)$ .

**I.** It follows immediately from the expression of  $h(t)$  that  $h'(t)$  exists for  $t \neq 1$  and that

$$h'(t) = \begin{cases} 2(t-1), & t > 1, \\ 0, & t < 1. \end{cases}$$

When we consider the point  $t = 1$  we are here forced to go back to the definition of the derivative as a limit of a difference quotient. Let  $\Delta t \neq 0$  denote the increment. Then

$$\frac{h(1 + \Delta t) - h(1)}{\Delta t} = \begin{cases} \frac{(\Delta t)^2 - 0}{\Delta t} = \Delta t, & \Delta t > 0, \\ 0, & \Delta t < 0. \end{cases}$$

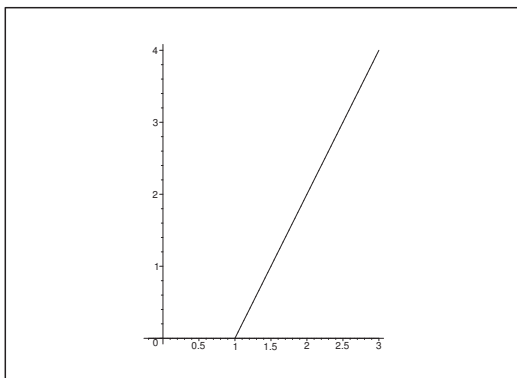
Figure 30: The graph of the derivative  $h'(t)$ .

When  $\Delta t \rightarrow 0$  through either positive or negative numbers, we get the same limit 0 in both cases. This means that  $h'(0)$  exists and its value is  $h'(0) = 0$ . Therefore,

$$h'(t) = \begin{cases} 2(t-1), & t \geq 1, \\ 0, & t < 1, \end{cases}$$

and it is obvious that both  $h(t)$  and  $h'(t)$  are continuous.

Since  $h(t) \geq 0$  and

$$\sqrt{h(t)} = \begin{cases} t-1 \quad (\geq 0), & \text{for } t \geq 1, \\ 0, & \text{for } t < 1 \end{cases} = \frac{1}{2} h'(t),$$

it follows that  $x = h(t)$  is a solution of

$$(8) \quad \frac{dx}{dt} = 2\sqrt{x}, \quad x \geq 0, \quad t \in \mathbb{R}.$$

On the other hand it is also obvious that  $x = 0$  is a solution of (8) and that  $x = 0$  trivially is 0 for  $t = 1$ .

The *Existence and Uniqueness Theorem* is describing the conditions for existence and uniqueness of solutions of differential equations of the form

$$\frac{dx}{dt} = \varphi(t) \psi(x), \quad t \in J_1, \quad x \in J_2.$$

The *assumption* in the *Existence and Uniqueness Theorem* is that

$$\psi(x) \neq 0 \quad \text{for every } x \in J_2.$$

In the case under consideration we have

$$\varphi(t) = 1 \quad \text{and} \quad \psi(x) = 2\sqrt{x}.$$

Therefore, since  $\psi(x) = 2\sqrt{x} = 0$  for  $x = 0$ , we *cannot* conclude that we have existence and uniqueness when  $x = 0$ .

When the *assumption* of some theorem (here the *Existence and Uniqueness Theorem*) is *not* fulfilled, it is *not* possible to conclude anything from this theorem, and hence it is no contradiction that we have two solution curves going through the same point.

REMARK. Arguments of the type above are in general considered as difficult, and even professional mathematicians may sometimes make an error in them. I have found a very well hidden example in *Andersen, Bohr & Petersen, Matematisk Analyse*, (a famous Danish textbook) where one would not expect to find such a fallacy.  $\diamond$

**Example 4.2** Consider the differential equation

$$\frac{dx}{dt} = g - kx^n,$$

where  $g$  and  $k$  are positive real numbers, and  $n$  is a natural number. Show that there exists a constant solution  $x = K$  of the differential equation, and show that the graph of any other solution either lies above or below the straight line  $x = K$ .

- A. A nonlinear differential equation of first order, where the variables can be separated. Are there any constant solutions? Where are the graphs of the other solutions?
- D. Put  $x = K$  and then solve with respect to  $K$ . Divide into the two cases of  $n$  even and  $n$  odd. Apply the Existence and Uniqueness Theorem in order to conclude how the other solutions behave compared with the constant solution.
- I. REMARK. When  $x$  satisfies  $g - k \cdot x^n \neq 0$ , we get by a separation of the variables that

$$\frac{1}{g - k \cdot x^n} \frac{dx}{dt} = 1,$$

hence by an integration,

$$\int \frac{dx}{g - k \cdot x^n} = t + c.$$

When  $g$  and  $k$  and  $n$  are given numbers, we can *in principle* calculate the integral by first decomposing the integrand. Unfortunately, we get by this procedure the *inverse* function, i.e. we get  $t$  as a function of  $x$ . It is not a simple task afterwards to find  $x$  as a function of  $t$ , when  $n \neq 1$ . This is the reason why one is not asked to find the complete solution, and the example should rather demonstrate how one by some theoretical theorems is able to conclude something about the structure of the solutions.  $\diamond$

When we put  $x = K$  into the differential equation we get  $0 = g - k \cdot K^n$ , hence

$$K^n = \frac{g}{k} > 0.$$

Then we split the investigation into the cases of  $n$  even/odd.

- 1) When  $n = 2m + 1$  is odd, we get one solution,

$$K = \sqrt[2m+1]{\frac{g}{k}} > 0.$$

2) When  $n = 2m$  is even we get two solutions,

$$K = \pm \sqrt[2m]{\frac{g}{k}}.$$

In both cases we have  $\frac{dx}{dt} = 0$ .

Obviously  $f(x) = g - k \cdot x^n$  is continuous, so we have to go through the following discussion of the slopes of the solution curves. Again we shall split into  $n$  odd/even.

Please click the advert

# CHALLENGE YOURSELF

## WWW.STUDYINSWEDEN.SE

**Si.**  
Swedish Institute

Today's job market values ambitious, innovative, perceptive team players. Swedish universities foster these qualities through a forward-thinking culture where you're close to the latest ideas and global trends.

Whatever your career goals may be, studying in Sweden will give you valuable skills and a competitive advantage for your future. [www.studyinsweden.se](http://www.studyinsweden.se)

Download free books at [BookBooN.com](http://BookBooN.com)



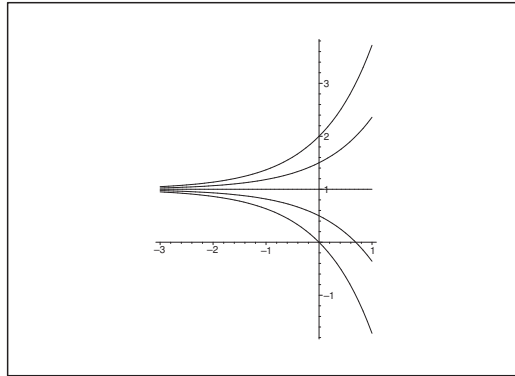

Figure 31: The solutions curves for  $\frac{dx}{dt} = 1 - x$ , i.e.  $g = 1 = k$  and  $n = 1$  odd.

1) When  $n = 2m + 1$  is odd, then

$$\frac{dx}{dt} = g - k \cdot x^n \begin{cases} < 0 \text{ for } x \in \left[ \sqrt[n]{\frac{g}{k}}, +\infty \right), \\ > 0 \text{ for } x \in \left( -\infty, \sqrt[n]{\frac{g}{k}} \right]. \end{cases}$$

According to the *Existence and Uniqueness Theorem* every non-constant solution will either be decreasing everywhere and lie above the line  $x = \sqrt[n]{\frac{g}{k}}$ , or be increasing everywhere and lying below the line  $x = \sqrt[n]{\frac{g}{k}}$ .

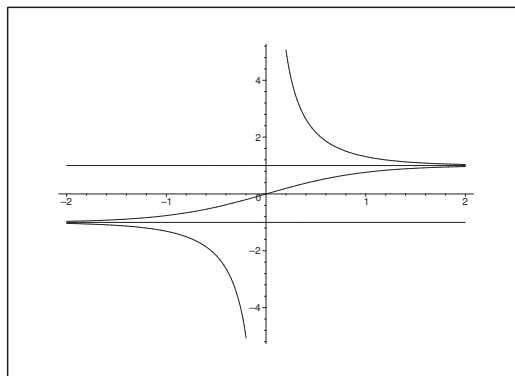

Figure 32: Solution curves for  $\frac{dx}{dt} = 1 - x^2$ , i.e.  $g = 1 = k$  and  $n = 2$  even.

2) When  $n = 2m$  is even, then

$$\frac{dx}{dt} = g - k \cdot x^n \quad \left\{ \begin{array}{l} < 0 \text{ for } x \in \left[ \sqrt[n]{\frac{g}{k}}, +\infty \right[ , \\ > 0 \text{ for } x \in \left] -\sqrt[n]{\frac{g}{k}}, \sqrt[n]{\frac{g}{k}} \right[ , \\ < 0 \text{ for } x \in \left] -\infty, -\sqrt[n]{\frac{g}{k}} \right[ . \end{array} \right.$$

According to the *Existence and Uniqueness Theorem* every non-constant solution will either be decreasing everywhere and lie above the line  $x = \sqrt[n]{\frac{g}{k}}$ , or be increasing everywhere and lying between the lines  $x = \sqrt[n]{\frac{g}{k}}$  and  $x = -\sqrt[n]{\frac{g}{k}}$ , or be decreasing everywhere and lying below the line  $x = -\sqrt[n]{\frac{g}{k}}$ .

REMARK. It is not difficult to prove that when  $x = f(t)$  is a solution of the differential equation then

$$x = g_c(t) = f(t + c)$$

is also a solution for any constant  $c \in \mathbb{R}$ , i.e. the solution graphs can be translated horizontally.  $\diamond$

**Example 4.3** 1) How many solutions do the differential equation

$$(9) \quad \frac{dx}{dt} = e^{t^2} x, \quad t \in \mathbb{R}$$

have?

Is the following claim correct or wrong: Whenever  $x_1(t)$  and  $x_2(t)$ ,  $t \in \mathbb{R}$  are any two solutions of (9), then  $x_1(t) + x_2(t)$  is also a solution of (9).

2) How many solutions do the differential equation

$$(10) \quad \frac{dx}{dt} = e^{t^2} x + 1, \quad t \in \mathbb{R}$$

have?

Is the following claim correct or wrong: Do there exist two solutions  $x_1(t)$  and  $x_2(t)$ ,  $t \in \mathbb{R}$ , such that  $x(t) = x_1(t) + x_2(t)$  is also a solution of (10)?

**A.** Linear homogeneous/inhomogeneous differential equation of first order.

**D.** It is possible to set up a solution formula for the complete solution. However, the integrations cannot be carried out, so the solutions cannot be expressed by known elementary functions. This does not matter here, because this is not what the task is about. We shall instead argue theoretically on the expression of the solution.

I. 1) Obviously,  $x = 0$  is a solution. If  $x \neq 0$ , then we divide  $x$ , getting

$$e^{t^2} = \frac{1}{x} \frac{dx}{dt} = \frac{d}{dt} \ln |x|,$$

hence by an integration,

$$\ln |x| = k + \int e^{t^2} dt,$$

and the complete solution is therefore then

$$x = c \cdot \exp \left( \int e^{t^2} dt \right), \quad c \in \mathbb{R},$$

with only one parameter  $c \in \mathbb{R}$ .

ALTERNATIVELY we apply the solution formula which of course will give the same expression.

It can be proved that the integral  $\int e^{t^2} dt$  cannot be expressed by known elementary functions. However, an exact expression of the function is not necessary for the following discussion.

Since the equation is homogeneous, we obviously find that if

$$x_1(t) = c_1 \cdot \exp \left( \int e^{t^2} dt \right), \quad x_2(t) = c_2 \cdot \exp \left( \int e^{t^2} dt \right)$$

are solutions, then

$$x(t) = x_1(t) + x_2(t) = (c_1 + c_2) \cdot \exp \left( \int e^{t^2} dt \right)$$

is also a solution of the homogeneous equation, so the claim is correct.

2) The equation is linear and inhomogeneous. The structure of the solution is

$$x(t) = c \cdot \exp \left( \int e^{t^2} dt \right) + \exp \left( \int e^{t^2} dt \right) \cdot \int \exp \left( - \int e^{t^2} dt \right) dt,$$

which cannot either be expressed by means of known elementary functions. The complete solution again only depends on one parameter  $c \in \mathbb{R}$ .

Since the equation is inhomogeneous, the latter claim is wrong. Just let  $x_1(t)$  and  $x_2(t)$  be solutions of the equation, which here is written in the equivalent form

$$\frac{dx}{dt} - e^{t^2} x = 1.$$

Then by an insertion of  $x(t) = x_1(t) + x_2(t)$  we get that

$$\begin{aligned} \frac{dx}{dt} - e^{t^2} x &= \frac{d}{dt} (x_1 + x_2) - e^{t^2} (x_1 + x_2) \\ &= \left\{ \frac{dx_1}{dt} - e^{t^2} x_1 \right\} + \left\{ \frac{dx_2}{dt} - e^{t^2} x_2 \right\} \\ &= 1 + 1 = 2 \neq 1. \end{aligned}$$

Since  $x_1$  and  $x_2$  were any solutions of the inhomogeneous equation it follows that the claim is not true for any pair of solutions  $(x_1, x_2)$ .

**Example 4.4** Show by insertion that the equation

$$(11) \quad \frac{dx}{dt} + p(t)x = q(t), \quad t \in I,$$

for every value of the constant  $c$  has the solution

$$(12) \quad x = e^{-P(t)} \left\{ \int e^{P(t)} q(t) dt + c \right\}, \quad t \in I, \quad c \in \mathbb{R},$$

where  $P(t) = \int p(t) dt$ .

Is this a new proof of theorem 1.2?

A. Testing a solution.

D. Insert (12) into (11) and reduce.

I. We first calculate

$$\begin{aligned} \frac{dx}{dt} &= -p(t)x + e^{-P(t)} \left\{ e^{P(t)} q(t) + 0 \right\} \\ &= -p(t)x + q(t), \end{aligned}$$

Please click the advert

www.job.oticon.dk

**oticon**  
PEOPLE FIRST

hence by a rearrangement

$$\frac{dx}{dt} + p(t)x = q(t),$$

and we have proved the first claim.

Of course we have *not* given a new proof of theorem 1.2. We have only shown that (12) describes some solutions of (11). We are still missing the proof of that we get *all* solutions in this way. This requires another argument.

**Example 4.5** Does there exist a differential equation of the form

$$(13) \quad \frac{dx}{dt} + p(t)x = q(t), \quad t \in I,$$

which has the functions

$$x = t^2, \quad t \in \mathbb{R}, \quad \text{and} \quad x = t^3, \quad t \in \mathbb{R},$$

as two of its solutions?

**A.** Given solutions of an unknown linear differential equation of first order.

**D.** Insert the two given functions into (13), i.e.

$$\frac{dx}{dt} + p(t)x = q(t),$$

and try to identify  $p(t)$  and  $q(t)$ .

**I.** When we insert  $x = t^2$ , resp.  $x = t^3$ , into the differential equation we get

$$\begin{aligned} x = t^2 : \quad 2t + t^2 p(t) &= q(t), & \text{i.e.} \quad 2t^2 + t^3 p(t) &= t q(t), \\ x = t^3 : \quad 3t^2 + t^3 p(t) &= q(t), & \text{i.e.} \quad 3t^2 + t^3 p(t) &= q(t), \end{aligned}$$

hence by a subtraction,  $t^2 = (1 - t)q(t)$ , so

$$q(t) = \frac{t^2}{1 - t}, \quad t \neq 1,$$

and  $3t^2 - 2t + (t^3 - t^2)p(t) = 0$ , thus

$$p(t) = \frac{2t - 3t^2}{t^3 - t^2} = \frac{t(2 - 3t)}{t^2(t - 1)} = \frac{2 - 3t}{t(t - 1)}, \quad \text{for } t \neq 0, 1.$$

We derive that a *candidate* of the unknown differential equation is

$$\frac{dx}{dt} + \frac{2 - 3t}{t(t - 1)} x = \frac{t^2}{1 - t}, \quad \text{for } t \neq 0, 1.$$

It follows from this that there does not exist any equation of the form (13) for  $t \in \mathbb{R}$ , because we must assume that  $t \neq 0$  and  $t \neq 1$ . On the other hand, we obtain something acceptable if we multiply the equation by  $t(t-1)$ . Then

$$t(t-1) \frac{dx}{dt} + (2-3t)x = -t^3, \quad t \in \mathbb{R},$$

which is defined in the whole of  $\mathbb{R}$ .

If we have “solved” the problem can only be decided by the

**C. TEST.** If  $x = t^2$ , then the left hand side is

$$\begin{aligned} t(t-1) \frac{dx}{dt} + (2-3t)x \\ = t(t-1) \cdot 2t + (2-3t) \cdot t^2 = 2t^3 - 2t^2 + 2t^2 - 3t^3 = -t^3, \end{aligned}$$

and we see that  $x = t^2$  is a solution of the found differential equation.

When  $x = t^3$  we get for the left hand side

$$\begin{aligned} t(t-1) \frac{dx}{dt} + (2-3t)x \\ = t(t-1) \cdot 3t^2 + (2-3t) \cdot t^3 = 3t^4 - 3t^3 + 2t^3 - 3t^4 = -t^4, \end{aligned}$$

so  $x = t^3$  is also a solution of the modified equation.

**CONCLUSION:** There exists no equation of the form (13), defined for every  $t \in \mathbb{R}$ , such that  $x = t^2$  and  $x = t^3$  both are solutions. However, if we exclude the two points  $t = 0$  and  $t = 1$ , or **ALTERNATIVELY** multiply the candidate by  $t(t-1)$ , then we get a modified equation which has the two solutions for  $t \neq 0$  og  $t \neq 1$ .

## 5 The Bernoulli differential equation

**Example 5.1** Let  $x = \varphi(t)$  denote the solution of the differential equation

$$\frac{dx}{dt} + x = x^2, \quad x > 0, \quad t \in \mathbb{R},$$

for which  $\varphi(0) = \frac{1}{2}$ . Show that  $y = \{\varphi(t)\}^{-1}$  satisfies the differential equation

$$\frac{dy}{dt} - y = -1,$$

and find  $\varphi(t)$ .

- A.** The equation is a nonlinear differential equation of first order (a so-called *Bernoulli differential equation*), which by a rearrangement can be written in a form, in which the variables can be separated.
- D.** There are several possibilities of solution, like e.g.
- 1) Follow the description above.
  - 2) Divide by  $-x^2$  and reduce.
  - 3) Separate the variables.

Please click the advert



**CHALLENGE  
YOURSELF**

**WWW.STUDYINSWEDEN.SE**

Today's job market values ambitious, innovative, perceptive team players. Swedish universities foster these qualities through a forward-thinking culture where you're close to the latest ideas and global trends.

Whatever your career goals may be, studying in Sweden will give you valuable skills and a competitive advantage for your future. [www.studyinsweden.se](http://www.studyinsweden.se)

**Si.**  
Swedish Institute

Download free books at [BookBooN.com](http://BookBooN.com)

**I. First solution.** *The suggested procedure.*

When  $x = \varphi(t) > 0$ , then

$$y = \{\varphi(t)\}^{-1} = \frac{1}{x} > 0, \quad \text{and} \quad x = \frac{1}{y}.$$

By insertion we get

$$\begin{aligned} 0 &= \frac{dx}{dt} + x - x^2 = \frac{d}{dt} \left( \frac{1}{y} \right) + \frac{1}{y} - \frac{1}{y^2} \\ &= -\frac{1}{y^2} \frac{dy}{dt} + \frac{1}{y} - \frac{1}{y^2}. \end{aligned}$$

When this equation is multiplied by  $-y^2 < 0$ , we obtain the equivalent equation

$$\frac{dy}{dt} - y + 1 = 0, \quad y > 0,$$

which we rewrite in the form

$$\frac{dy}{dt} - y = -1, \quad y > 0,$$

i.e. a linear differential equation of first order with constant coefficients.

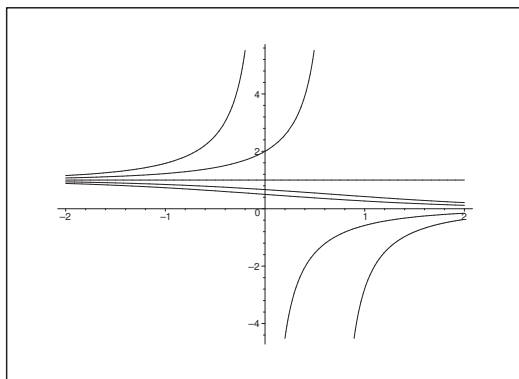

Figure 33: Some solution curves.

The complete solution of the corresponding homogeneous  $y$ -equation is seen by inspection to be  $c \cdot e^t$ . Another simple inspection gives that  $y = 1$  is a particular solution. According to theorem 1.3 the complete solution of the  $y$ -equation is given by

$$y = 1 + c \cdot e^t, \quad c \in \mathbb{R}, \quad y > 0, \quad t \in I_c,$$

where every  $t \in I_c$  satisfies the condition  $1 + c \cdot e^t > 0$ .

Since  $x = \frac{1}{y}$  we get that the original *nonlinear*  $x$ -equation has the complete solution

$$x = \varphi(t) = \frac{1}{1 + c \cdot e^t}, \quad c \in \mathbb{R}, \quad 1 + c \cdot e^t > 0.$$



It follows from the initial condition  $\varphi(0) = \frac{1}{2}$  that  $\varphi(0) = \frac{1}{2} = \frac{1}{1+c}$ , so  $c = 1$ , and the condition  $0 < 1 + c \cdot e^t = 1 + e^t$  is seen to be fulfilled for every  $t \in \mathbb{R}$ .

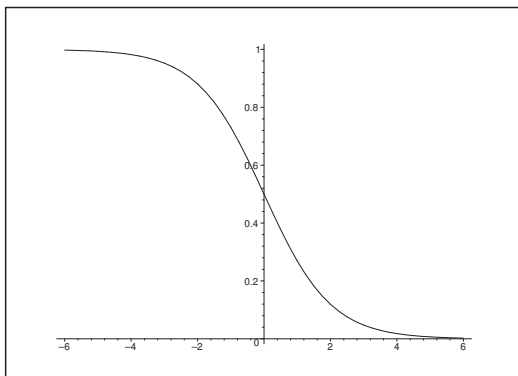

Figure 34: The graph of the solution  $\varphi(t) = \frac{1}{1+e^t}$ .

Therefore, the solution is

$$\varphi(t) = \frac{1}{1+e^t}, \quad t \in \mathbb{R}.$$

**Second solution.** When we divide the equation by  $-x^2 \neq 0$ , we get

$$-1 = -\frac{1}{x^2} \frac{dx}{dt} - \frac{1}{x} = \frac{d}{dt} \left( \frac{1}{x} \right) - \frac{1}{x}.$$

Hence, by putting  $y = \frac{1}{x} > 0$  we obtain exactly the same as in the **first solution**. No need to repeat these calculations.

**Third solution.** *Separation of the variables.*

We get by a rearrangement

$$\frac{dx}{dt} = x^2 - x = x(x-1), \quad x > 0, \quad t \in \mathbb{R}.$$

It follows immediately that  $x = 1$  is a solution.

When  $x > 0$  we can separate the variables:

$$\frac{1}{x(x-1)} \frac{dx}{dt} = \left( -\frac{1}{x} + \frac{1}{x-1} \right) \frac{dx}{dt} = \frac{d}{dt} \left( \ln \left| \frac{x-1}{x} \right| \right) = 1,$$

hence by an integration,

$$\ln \left| \frac{x-1}{x} \right| = t + k, \quad \text{eller} \quad \left| \frac{x-1}{x} \right| = e^k \cdot e^t.$$

The sign of  $\frac{x-1}{x}$  is built into the constant  $-c$  ( $= \pm e^k$ ). Hence

$$\frac{x-1}{x} = 1 - \frac{1}{x} = -c \cdot e^t, \quad c \in \mathbb{R} \setminus \{0\}.$$

Since  $c = 0$  corresponds to the trivial solution  $x = 1$ , we can allow  $c \in \mathbb{R}$ .

By a rearrangement of the equation we get

$$\frac{1}{x} = 1 + c \cdot e^t, \quad c \in \mathbb{R}, \quad x > 0, \quad 1 + c \cdot e^t > 0,$$

i.e.

$$x = \frac{1}{1 + c \cdot e^t}, \quad c \in \mathbb{R}, \quad x > 0, \quad 1 + c \cdot e^t > 0.$$

Like in the **first solution** we use the initial conditions to get  $c = 1$ , and the wanted solution becomes

$$\varphi(t) = \frac{1}{1 + e^t}, \quad t \in \mathbb{R}.$$

**C.** Let  $\varphi(t) = \frac{1}{1 + c \cdot e^t}$ ,  $t \in I_c$ , where  $1 + c \cdot e^t > 0$ . Then

$$\begin{aligned} \frac{dx}{dt} + x &= -\frac{c \cdot e^t}{(1 + c \cdot e^t)^2} + \frac{1}{1 + c \cdot e^t} \\ &= \frac{(1 + c \cdot e^t) - c \cdot e^t}{(1 + c \cdot e^t)^2} = \left( \frac{1}{1 + c \cdot e^t} \right)^2 = x^2, \end{aligned}$$

and the differential equation is satisfied.

It is seen immediately that the initial condition is fulfilled for  $c = 1$ .

**Example 5.2** Let  $x = \varphi(t)$  denote the solution of the differential equation

$$\frac{dx}{dt} - x = \sqrt{x}, \quad x > 0, \quad t \in \mathbb{R},$$

for which  $\varphi(0) = \frac{1}{2}$ . Show that  $y = \{\varphi(t)\}^{\frac{1}{2}}$  satisfies the differential equation

$$\frac{dy}{dt} - \frac{1}{2}y = \frac{1}{2},$$

and find  $\varphi(t)$ .

**A.** The equation is a nonlinear differential equation of first order (a so-called *Bernoulli differential equation*), which by a rearrangement can be put in a form, in which the variables can be separated.

There is already given one solution method above.

**D.** We have several possibilities of solution, like e.g.:

- 1) Follow the method described above.
- 2) Divide by  $2\sqrt{x}$  and reduce.
- 3) Separate the variables.

**I. First solution.** *The indicated method.*

When  $x = \varphi(t) > 0$  we see that  $y = \sqrt{\varphi(t)} = \sqrt{x} > 0$  is defined and we get  $x = y^2$ . Then by an insertion into the equation,

$$\begin{aligned} 0 &= \frac{dx}{dt} - x - \sqrt{x} = \frac{d(y^2)}{dt} - y^2 - y \\ &= 2y \frac{dy}{dt} - y^2 - y = 2y \left\{ \frac{dy}{dt} - \frac{1}{2}y - \frac{1}{2} \right\}. \end{aligned}$$

Since  $2y \neq 0$ , this equation is equivalent to the linear differential equation of first order with constant coefficients

$$\frac{dy}{dt} - \frac{1}{2}y = \frac{1}{2}, \quad y > 0.$$

It is seen by *inspection* that  $y = -1$  is a solution and that the corresponding homogeneous equation has the complete solution  $c \cdot \exp\left(\frac{1}{2}t\right)$ . By theorem 1.3 we therefore get the complete solution of the inhomogeneous equation

$$y = -1 + c \cdot \exp\left(\frac{1}{2}t\right), \quad \text{for } y > 0 \text{ and } -1 + c \cdot \exp\left(\frac{1}{2}t\right) > 0.$$

Please click the advert

## Turning a challenge into a learning curve. Just another day at the office for a high performer.

### Accenture Boot Camp – your toughest test yet

Choose Accenture for a career where the variety of opportunities and challenges allows you to make a difference every day. A place where you can develop your potential and grow professionally, working alongside talented colleagues. The only place where you can learn from our unrivalled experience, while helping our global clients achieve high performance. If this is your idea of a typical working day, then Accenture is the place to be.

It all starts at Boot Camp. It's 48 hours that will stimulate your mind and enhance your career prospects. You'll spend time with other students, top Accenture Consultants and special guests. An inspirational two days

packed with intellectual challenges and activities designed to let you discover what it really means to be a high performer in business. We can't tell you everything about Boot Camp, but expect a fast-paced, exhilarating

and intense learning experience. It could be your toughest test yet, which is exactly what will make it your biggest opportunity.

Find out more and apply online.

**Visit [accenture.com/bootcamp](https://www.accenture.com/bootcamp)**

• Consulting • Technology • Outsourcing

**accenture**  
*High performance. Delivered.*

From  $x = y^2$  we get that the complete solution of the original nonlinear differential equation is

$$x = \left(-1 + c \cdot \exp\left(\frac{1}{2}t\right)\right)^2, \quad \text{for } c > \exp\left(-\frac{1}{2}t\right).$$

The condition on  $t$  and  $c$  is important. If it is not fulfilled, we get wrong solutions. We see that  $c > 0$ , and when this is the case, then

$$t > 2 \ln \frac{1}{c} = -2 \ln c.$$

It follows from the initial condition  $\varphi(0) = \frac{1}{2}$  that  $0 > -2 \ln c$ , i.e.  $c > 1$  and  $(-1 + c)^2 = \frac{1}{2}$ , so

$$c = 1 + \frac{1}{\sqrt{2}} \quad (> 1).$$

The wanted solution is then

$$x = \left\{ \left(1 + \frac{1}{\sqrt{2}}\right) \exp\left(\frac{1}{2}t\right) - 1 \right\}^2, \quad t \in \left] -2 \ln \left(1 + \frac{1}{\sqrt{2}}\right), +\infty \right[.$$

**Second solution.** A rearrangement and a division by  $2\sqrt{x}$  give

$$0 = \frac{1}{2\sqrt{x}} \frac{dx}{dt} - \frac{1}{2} \sqrt{x} - \frac{1}{2} = \frac{d(\sqrt{x})}{dt} - \frac{1}{2} \sqrt{x} - \frac{1}{2}.$$

When we use the substitution  $y = \sqrt{x}$ , we are back in the case of the **first solution**. It is then no need to repeat the following calculations.

**Third solution.** Separation of the variables.

It follows from the rearrangement

$$\frac{dx}{dt} = x + \sqrt{x} = \sqrt{x}(\sqrt{x} + 1), \quad x > 0,$$

that

$$1 = \frac{1}{\sqrt{x}(\sqrt{x} + 1)} \frac{dx}{dt} = 2 \frac{1}{\sqrt{x} + 1} \frac{d(\sqrt{x})}{dt} = 2 \frac{d}{dt} \{ \ln(\sqrt{x} + 1) \}.$$

Then by an integration

$$\ln(\sqrt{x} + 1) = \frac{1}{2}t + k,$$

so

$$\sqrt{x} + 1 = c \cdot \exp\left(\frac{1}{2}t\right), \quad c > 0,$$

hence

$$\sqrt{x} = c \cdot \exp\left(\frac{1}{2}t\right) - 1 \quad (> 0), \quad c > 0, \quad \exp\left(\frac{1}{2}t\right) > \frac{1}{c},$$

i.e.  $t > 2 \ln \frac{1}{c} = -2 \ln c$ .

Then we get by a squaring

$$x = \left\{ c \cdot \exp\left(\frac{1}{2}t\right) - 1 \right\}^2, \quad \text{for } c > 0 \text{ og } t \in ] -2 \ln c, +\infty[.$$

For the initial value problem we must have  $0 > -2 \ln c$ , i.e.  $c > 1$ , so  $\varphi(0) = \frac{1}{2} = \{c - 1\}^2$ , and thus  $c = 1 + \frac{1}{\sqrt{2}}$ . The solution is then

$$\varphi(t) = \left\{ \left(1 + \frac{1}{\sqrt{2}}\right) \exp\left(\frac{1}{2}t\right) - 1 \right\}^2, \quad t \in \left] -2 \ln \left(1 + \frac{1}{\sqrt{2}}\right), +\infty \right[.$$

**C.** Let  $x = \varphi(t) = \left\{ c \cdot \exp\left(\frac{1}{2}t\right) - 1 \right\}^2$ ,  $t > -2 \ln c$ . Then in particular,

$$\sqrt{x} = c \cdot \exp\left(\frac{1}{2}t\right) - 1.$$

By insertion into the left hand side of the differential equation we get

$$\begin{aligned} \frac{dx}{dt} - x &= 2 \left\{ c \cdot \exp\left(\frac{1}{2}t\right) - 1 \right\} \cdot c \cdot \frac{1}{2} \exp\left(\frac{1}{2}t\right) - \left\{ c \cdot \exp\left(\frac{1}{2}t\right) - 1 \right\}^2 \\ &= \left\{ c \cdot \exp\left(\frac{1}{2}t\right) - 1 \right\} \left\{ 2 \cdot c \cdot \frac{1}{2} \cdot \exp\left(\frac{1}{2}t\right) - c \cdot \exp\left(\frac{1}{2}t\right) + 1 \right\} \\ &= c \cdot \exp\left(\frac{1}{2}t\right) - 1 = \sqrt{x}, \end{aligned}$$

and we see that the differential equation is satisfied.

For  $c = 1 + \frac{1}{\sqrt{2}}$  it is seen that

$$0 \in \left] -2 \ln \left(1 + \frac{1}{\sqrt{2}}\right), +\infty \right[ ,$$

and that  $\varphi(0) = \frac{1}{2}$ .

**Example 5.3** Consider a differential equation of the form

$$(14) \quad \frac{dx}{dt} + p(t)x = q(t)x^\alpha, \quad x > 0, \quad t \in \mathbb{R},$$

where  $\alpha$  is a real constant. Show that if we put  $y = x^{1-\alpha}$ , then (14) is transferred into a linear differential equation of first order in the unknown function  $y$ , and specify this equation.

**A.** *Solution formula for a general Bernoulli differential equation.* A method of solution is sketched. This method does not work for  $\alpha = 1$ , because then  $y \equiv 1$ . But when  $\alpha = 1$ , we see that (14) is linear, so it is possible to apply another and simpler method.

Note also that when  $\alpha = 0$  we can either use the method indicated above, or we can consider the equation as a linear and inhomogeneous differential equation of first order, i.e. we can use the usual solution formula. When  $\alpha = 0$  we therefore can choose between two methods, of which the latter is the easiest one to apply.

**D.** Follow the sketched method under the condition that  $\alpha \neq 1$ .

**I.** Let  $\alpha \in \mathbb{R} \setminus \{1\}$ . If  $x > 0$ , then

$$y = x^{1-\alpha} > 0 \quad \text{and} \quad x = y^{\frac{1}{1-\alpha}}.$$

By insertion into (14) we get after a rearrangement,

$$\begin{aligned} 0 &= \frac{dx}{dt} + p(t)x - q(t)x^\alpha \\ &= \frac{d}{dt} \left( y^{\frac{1}{1-\alpha}} \right) + p(t)y^{\frac{1}{1-\alpha}} - q(t)y^{\frac{\alpha}{1-\alpha}} \\ &= \frac{1}{1-\alpha} \cdot y^{\frac{1}{1-\alpha}-1} \cdot \frac{dy}{dt} + p(t)y^{\frac{1}{1-\alpha}} - q(t)y^{\frac{\alpha}{1-\alpha}} \\ &= \frac{1}{1-\alpha} \cdot y^{\frac{\alpha}{1-\alpha}} \left\{ \frac{dy}{dt} + (1-\alpha)p(t)y - (1-\alpha)q(t) \right\}. \end{aligned}$$

Since

$$\frac{1}{1-\alpha} \cdot y^{\frac{\alpha}{1-\alpha}} \neq 0,$$

we see that (5.3) is equivalent to the linear and inhomogeneous differential equation of first order

$$(15) \quad \frac{dy}{dt} + (1-\alpha)p(t)y = (1-\alpha)q(t), \quad y > 0, \quad y = x^{1-\alpha}. \quad \diamond$$

**REMARK.** In practice it is easiest to solve (14) by first dividing by the unpleasant expression  $x^\alpha$  and then reduce. It follows from

$$\frac{1}{x^\alpha} \frac{dx}{dt} = \frac{1}{1-\alpha} \frac{dx^{1-\alpha}}{dt}$$

that  $y = x^{1-\alpha}$  is a very natural new variable, so in this case we do not have to remember the solution formula (15), only to use one's common sense.  $\diamond$

**Example 5.4** Consider the differential equation

$$(16) \quad t \frac{dx}{dt} - \frac{1}{2}x = \frac{t^2}{2} \frac{1}{x}, \quad x > 0, \quad t \in \mathbb{R}.$$

1) Prove that  $x = \varphi(t)$  is a solution of (16), if and only if  $y = \{\varphi(t)\}^2$  is a solution of

$$(17) \quad t \frac{dy}{dt} - y = t^2.$$

2) Find the complete solution of (17) in each of the intervals  $t \in ]-\infty, 0[$  and  $t \in ]0, +\infty[$ .

3) Find the solution  $x = f(t)$  of (16), for which  $f(1) = 2$ , and the solution  $x = g(t)$ , for which  $g(-2) = 2$ . Specify in particular the definition intervals of the solutions.

4) Does (16) have any solution, which is defined in a neighbourhood of  $t = 0$ ?

5) Show that for every point  $(t_0, x_0)$  with  $t_0 \neq 0$  there exists precisely one solution  $x = \varphi(t)$  of (16), for which  $\varphi(t_0) = x_0$ .

**A.** A nonlinear equation of first order of the type

$$a(t) \frac{dx}{dt} + b(t)x = c(t)x^\alpha.$$

When  $\alpha = 0$  or  $1$ , then the equation is linear. When  $\alpha \neq 0, 1$ , it is called a *Bernoulli differential equation*. Such an equation can always be solved. There is here indicated a solution procedure. In the general method, which is not described explicitly, we divide by  $x^\alpha$  for  $x \neq 0$  and then rewrite the equation to a differential equation in  $y = x^{1-\alpha}$ .

Please click the advert



it's an **interesting** world

## Get under the skin of it.

**Graduate opportunities**  
Cheltenham | £24,945 + benefits

One of the UK's intelligence services, GCHQ's role is two-fold: to gather and analyse intelligence which helps shape Britain's response to global events, and, to provide technical advice for the protection of Government communication and information systems. In doing so, our specialists – in IT, internet, engineering, languages, information assurance, mathematics and intelligence – get well beneath the surface of global affairs. If you thought the world was an interesting place, you really ought to explore our world of work.

[www.careersinbritishintelligence.co.uk](http://www.careersinbritishintelligence.co.uk)

Applicants must be British citizens. GCHQ values diversity and welcomes applicants from all sections of the community. We want our workforce to reflect the diversity of our work.



- D.** 1) Multiply (16) by  $2x$  and reduce.  
 2) Solve (17) for  $t \neq 0$ .  
 3) Apply the initial conditions and find two different particular solutions.  
 4) Investigate what happens in the neighbourhood of  $t = 0$ . (Consider in particular  $\frac{dx}{dt}$ ).  
 5) Show the existence and uniqueness of the solution through any point  $(t_0, x_0)$ , where  $t_0 \neq 0$  and  $x_0 > 0$ .

- I.** 1) When (16) is multiplied by  $2x > 0$ , we obtain the equivalent equation

$$0 = t \cdot 2x \frac{dx}{dt} - \frac{1}{2} \cdot 2x \cdot x - \frac{t^2}{2x} \cdot 2x = t \frac{d(x^2)}{dt} - x^2 - t^2.$$

Note that the multiplication by  $2x$  corresponds to a division by  $\frac{1}{2} \frac{1}{x}$ , hence a division by a constant times  $x^\alpha$ , because we have  $\alpha = -1$ .

When we put  $y = x^2 > 0$ , the equation above is reduced to (17), i.e.

$$t \frac{dy}{dt} - y = t^2.$$

- 2) When  $t \neq 0$ , we get by a division by  $t^2 > 0$  that (17) is equivalent to

$$1 = \frac{1}{t} \frac{dy}{dt} - \frac{1}{t^2} y = \frac{1}{t} \frac{dy}{dt} + \frac{d}{dt} \cdot y = \frac{d}{dt} \left( \frac{y}{t} \right),$$

hence by an integration

$$\frac{y}{t} = t - 2c, \quad \text{i.e.} \quad y = t^2 - 2ct = (t - c)^2 - c^2 \quad (> 0),$$

where the condition on  $t$  for any given  $c \in \mathbb{R}$  is that  $t(t - 2c) > 0$ , i.e. when  $t$  does *not* lie between 0 and  $2c$ .

- a) When  $c \geq 0$ , we get the possibilities  $t \in ]-\infty, 0[$  and  $t \in ]2c, +\infty[$ .  
 b) When  $c \leq 0$ , we get the possibilities  $t \in ]-\infty, 2c[$  and  $t \in ]0, +\infty[$ .

Hence the solutions are given by

$$y = t^2 - 2ct = (t - c)^2 - c^2, \quad \begin{cases} c \geq 0, & t \in ]-\infty, 0[, \\ c \geq 0, & t \in ]2c, +\infty[, \\ c \leq 0, & t \in ]-\infty, 2c[, \\ c \leq 0, & t \in ]0, +\infty[. \end{cases}$$

- 3) Since  $y = x^2$  and  $x > 0$ , it follows that

$$x = \sqrt{t^2 - 2ct} = \sqrt{(t - c)^2 - c^2}, \quad \begin{cases} c \geq 0, & t \in ]-\infty, 0[, \\ c \geq 0, & t \in ]2c, +\infty[, \\ c \leq 0, & t \in ]-\infty, 2c[, \\ c \leq 0, & t \in ]0, +\infty[. \end{cases}$$



REMARK. Since  $(t - c)^2 - x^2 = c^2$ , The solution curves are either  $x = |t|$  (for  $c = 0$ ) or parts of hyperbolic branches as sketched on the figure.

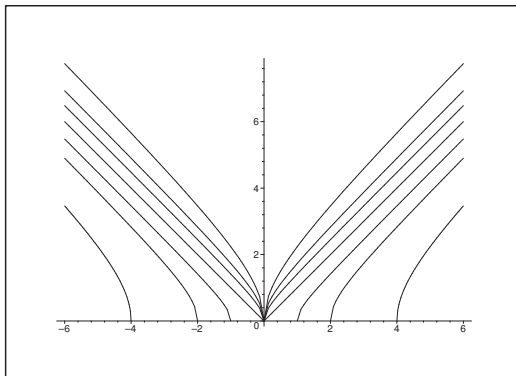

Figure 35: Sketch of some solution curves of the Bernoulli equation.

Apart from the half lines  $x = \pm t$ , every solution curve has a vertical half tangent, when the solutions tend to the  $t$ -axis.  $\diamond$

Let  $x = f(t)$  where  $f(1) = 1$ . Then

$$\{f(1)\}^2 = 4 = (c - 1)^2 - c^2 = -2c + 1, \quad \text{i.e. } c = -\frac{3}{2},$$

and since  $1 > 0$ , the solution with its corresponding domain is given by

$$f(t) = \sqrt{t^2 + 3t}, \quad t \in ]0, +\infty[.$$

When  $x = g(t)$  where  $g(-2) = 2$ , we get

$$\{g(-2)\}^2 = 4 = (-2)^2 + 2c = 4 + 2c, \quad \text{i.e. } c = 0.$$

When  $-2 < 0$ , the solution and its domain are given by

$$g(t) = \sqrt{t^2} = |t| = -t, \quad t < 0.$$

4) Let  $x = \sqrt{t^2 - 2ct}$ ,  $c \neq 0$ ,  $t(t - 2c) > 0$ . Then

$$\frac{dx}{dt} = \frac{t - c}{\sqrt{t(t - 2c)}},$$

hence

$$\left| \frac{dx}{dt} \right| \rightarrow +\infty \quad \text{for } t \rightarrow 0 \text{ in the interval.}$$

Therefore, any such solution curve has a vertical half tangent, when  $t \rightarrow 0$  in the domain, so it cannot be extended further.

When  $c = 0$ , we get  $x = |t|$ ,  $t \in ]-\infty, 0[$ , or  $t \in ]0, +\infty[$ . In these cases,

$$\frac{dx}{dt} = -1 \quad \text{for } t < 0, \quad \frac{dx}{dt} = +1 \quad \text{for } t > 0,$$

hence these solutions cannot be extended either across the vertical line  $t = 0$ .

We conclude that no composition of solutions is possible across  $t = 0$ , so no solution can be extended across the  $x$ -axis.

5) When  $t_0 \neq 0$  and  $x_0 > 0$ , we shall only prove that  $c \in \mathbb{R}$  is uniquely determined by

$$x_0 = \sqrt{t_0^2 - 2ct_0}.$$

This follows from

$$c = \frac{1}{2t_0} (t_0^2 - x_0^2).$$

Choosing this  $c$ , the solution is then given by

$$x = \sqrt{t^2 - 2ct}, \quad \begin{cases} t \in ]-\infty, \min(0, 2c)[, & \text{when } t_0 < 0, \\ t \in ]\max(0, 2c), +\infty[, & \text{when } t_0 > 0. \end{cases}$$

Please click the advert



**Brain power**

By 2020, wind could provide one-tenth of our planet's electricity needs. Already today, SKF's innovative know-how is crucial to running a large proportion of the world's wind turbines.

Up to 25 % of the generating costs relate to maintenance. These can be reduced dramatically thanks to our systems for on-line condition monitoring and automatic lubrication. We help make it more economical to create cleaner, cheaper energy out of thin air.

By sharing our experience, expertise, and creativity, industries can boost performance beyond expectations. Therefore we need the best employees who can meet this challenge!

**The Power of Knowledge Engineering**

Plug into The Power of Knowledge Engineering.  
Visit us at [www.skf.com/knowledge](http://www.skf.com/knowledge)

**SKF**

Download free books at [BookBooN.com](http://BookBooN.com)

## 6 The setup of model equations

**Example 6.1** A thermometer has for some time been in a room of the temperature  $21^\circ$ . The thermometer is then taken outside, where the temperature is  $3^\circ$ . After 3 minutes the thermometer shows  $8^\circ$ . We assume that the speed by which the temperature of the thermometer is proportional to the difference between the temperature of the environment and the temperature of the thermometer.

Find the temperature of the thermometer as a function of time.

For how long shall one wait until the thermometer only deviates by  $\frac{1}{2}^\circ$  from the true temperature?

**A.** Setup of a mathematical model followed by an application of this model.

**D.** Analyze the text and then setup the model. Solve the model equation in the given case.

**I.** Let  $x = f(t)$  denote the temperature and let  $t$  denote the time measured in minutes. Thus we put

$$f(0) = 21, \quad (\text{The thermometer is taken outside to time } t = 0)$$

$$f(3) = 8, \quad (\text{the thermometer is read to the time } t = 3).$$

The velocity  $f'(t)$ , by which the temperature of the thermometer is changed is proportional (proportional factor  $k$ ) to the difference between the temperature of the environment,  $3^\circ$ , and the temperature of the thermometer  $f(t)$  itself, i.e.  $f'(t)$  is proportional to  $3 - f(t)$ . This shows that the model can be described by the differential equation

$$f'(t) = k \cdot \{3 - f(t)\}.$$

The task is now to find the constant  $k$  and the solution  $x = f(t)$ ,  $t \geq 0$ , where

$$\begin{cases} \frac{dx}{dt} = -kx + 3k, \\ f(0) = 21, \quad f(3) = 8. \end{cases}$$

Since the constant  $k$  is unknown we must require two (boundary) conditions.

We first solve the linear equation

$$\frac{dx}{dt} + k \cdot x = 3k, \quad t \geq 0.$$

We just guess  $x = e^{-kt}$  as a solution of the corresponding homogeneous equation and  $x = 3$  as a particular solution. (This should not be too surprising.)

By theorem 1.3 the complete solution is then

$$(18) \quad x = f(t) = 3 + c \cdot e^{-kt}, \quad t \geq 0.$$

The two constants  $c$  and  $e^{-k}$  are then found from:

$$21 = f(0) = 3 + c, \quad 8 = f(3) = 3 + c \cdot e^{-3k}.$$

Thus  $c = 18$  and  $e^{-3k} = \frac{8-3}{18} = \frac{5}{18}$ , i.e.

$$e^{-k} = \sqrt[3]{\frac{5}{18}} \quad \text{or} \quad k = \frac{1}{3} \ln\left(\frac{18}{5}\right).$$

By insertion into (18) we get the solution

$$x = f(t) = 3 + 18 \cdot \left(\sqrt[3]{\frac{5}{18}}\right)^t, \quad t \geq 0,$$

which is equivalent to

$$x = f(t) = 3 + 18 \exp\left(-\frac{t}{3} \ln\left(\frac{18}{5}\right)\right), \quad t \geq 0.$$

Then assume that the thermometer deviates less than  $\frac{1}{2}^\circ$  from the temperature of the environment. Since the thermometer is, by the start of the problem, always showing a higher temperature than the environment we must have

$$0 < 18 \cdot \exp\left(-\frac{t}{3} \ln\left(\frac{18}{5}\right)\right) \leq \frac{1}{2},$$

i.e.

$$\exp\left(\frac{t}{3} \ln\left(\frac{18}{5}\right)\right) \geq 36,$$

from which

$$t \geq 3 \cdot \frac{\ln(36)}{\ln\left(\frac{18}{5}\right)} \approx 8,39 \text{ min.}$$

**C. TEST.** Let us check that our function satisfies the differential equation. Put

$$x = f(t) = 3 + 18 \exp\left(-\frac{t}{3} \ln\left(\frac{18}{5}\right)\right), \quad t \geq 0,$$

and let

$$k = \frac{1}{3} \ln\left(\frac{18}{5}\right).$$

Then

$$f(0) = 3 + 18 = 21 \quad \text{og} \quad f(3) = 3 + 18 \exp\left(-\ln\left(\frac{18}{5}\right)\right) = 3 + 18 \cdot \frac{5}{18} = 8,$$

and be see that the two (boundary) conditions are fulfilled.

We then get by a differentiation,

$$\begin{aligned} \frac{dx}{dt} &= 18 \exp\left(-\frac{t}{3} \ln\left(\frac{18}{5}\right)\right) \cdot \left(-\frac{1}{3} \ln\left(\frac{18}{5}\right)\right) \\ &= (x-3) \cdot (-k) = k \cdot (3-x), \end{aligned}$$

which is precisely the differential equation of the model.

Thus our solution is correct.

**Example 6.2** Let  $x(t)$  denote the population of a country at time  $t$ . We assume that the population increase  $\Delta x$  in a short interval of time is (approximately) proportional to the length of this interval of time  $\Delta t$  as well as to the population  $x(t)$  by the start of this short interval of time,

$$\Delta x = k \cdot x(t) \cdot \Delta t,$$

where  $k$  is some given factor of proportionality.

- 1) Set up a differential equation which describes  $x(t)$ .
- 2) Assume that the population is doubled in 50 years. When will the population be tripled?

**A.** 1) Setting up a mathematical model.

- 2) Apply the model in a specific given situation.

**D.** 1) Analyze the text in order to set up the differential equation.

- 2) Find the constant from the given addition condition and then solve the solution with respect to time.

**I.** 1) Let  $f(t)$  denote the number of inhabitants to time  $t$ . Then the increase of population

$$\Delta f(t) = f(t + \Delta t) - f(t)$$

in a small interval of time of length  $\Delta t > 0$  is proportional (with some unknown factor  $k$ ) to the length  $\Delta t$  of the time interval and the number  $f(t)$  of inhabitants, i.e.

$$f(t + \Delta t) - f(t) \approx k \cdot \Delta t \cdot f(t),$$

where we can replace  $\approx$  by  $=$ , if we add a term of the type  $o(\Delta t)$  on the right hand side.

A division by  $\Delta t > 0$  followed by taking the limit  $\Delta t \rightarrow 0$  then gives

$$\lim_{\Delta t \rightarrow 0} \frac{f(t + \Delta t) - f(t)}{\Delta t} = f'(t) = k \cdot f(t),$$

which means that the model of the increase of the population under the given circumstances can be described by the linear homogeneous differential equation of first order (we write  $x = f(t)$ ) with constant coefficients,

$$\frac{dx}{dt} = k \cdot x, \quad x > 0, \quad t \in \mathbb{R}.$$

The complete solution of this equation is

$$x = c \cdot e^{kt}, \quad c > 0, \quad t \in \mathbb{R}.$$

- 2) Let  $c > 0$  be the number of inhabitants at time  $t = 0$  years. The assumption that the population is doubled in 50 years can then be written

$$f(50) = c \cdot e^{50k} = 2c,$$

hence

$$k = \frac{1}{50} \ln 2 \quad (\approx 0,0139).$$

By choosing this  $k$  in the following, we then want to find  $t$ , such that

$$f(t) = c e^{kt} = 3c.$$

This is easy. We find  $kt = \ln 3$ , i.e.

$$t = \frac{1}{k} \ln 3 = 50 \cdot \frac{\ln 3}{\ln 2} \approx 79,25 \text{ år.}$$

## Trust and responsibility

NNE and Pharmaplan have joined forces to create NNE Pharmaplan, the world's leading engineering and consultancy company focused entirely on the pharma and biotech industries.

Inés Aréizaga Esteva (Spain), 25 years old  
Education: Chemical Engineer

– You have to be proactive and open-minded as a newcomer and make it clear to your colleagues what you are able to cope. The pharmaceutical field is new to me. But busy as they are, most of my colleagues find the time to teach me, and they also trust me. Even though it was a bit hard at first, I can feel over time that I am beginning to be taken seriously and that my contribution is appreciated.

Please click the advert



NNE Pharmaplan is the world's leading engineering and consultancy company focused entirely on the pharma and biotech industries. We employ more than 1500 people worldwide and offer global reach and local knowledge along with our all-encompassing list of services.  
[nnepharmaplan.com](http://nnepharmaplan.com)

nne pharmaplan®

**Example 6.3** A vertical cylindrical tank of radius  $R$  and height  $h_0$  is filled with water. At time  $t = 0$  a circular hole of radius  $r$  is opened in the bottom of the tank, and the water pours out under the gravitational pull. If  $h(t)$  denotes the height of the water inside the tank at time  $t$ , then we can derive from physics (Torricelli's law) the differential equation

$$\frac{dh}{dt} = -\frac{r^2}{R^2} \sqrt{2gh(t)}, \quad t \geq 0,$$

where  $g$  denotes the gravitation. Find the function  $h(t)$ .

**A.** In this case the differential equation is *given* so we shall *not* derive it. It is a nonlinear equation of the type, where we can separate the variables.

**D.** Solve the differential equation by separation for the initial condition  $h(0) = h_0$ .

**I.** Let  $x = h(t) \geq 0$  denote the height of the water column to time  $t \geq 0$ , measured from the bottom. Then  $h(0) = h_0$ , and we shall solve the slightly rearranged differential equation

$$(19) \quad \frac{dx}{dt} = -\frac{r^2}{R^2} \sqrt{\frac{g}{2}} \cdot 2\sqrt{x}, \quad x \geq 0, \quad t \geq 0,$$

with the initial condition  $x = h(0) = h_0$ .

The equation (19) has the trivial solution  $x = 0$ , which does not satisfy the initial conditions. When  $x > 0$  we can separate the variables. Dividing (6.3) by  $2\sqrt{x}$  we get

$$\frac{1}{2\sqrt{x}} \frac{dx}{dt} = \frac{d(\sqrt{x})}{dt} = -\frac{r^2}{R^2} \sqrt{\frac{g}{2}},$$

thus by a simple integration,

$$\sqrt{x} = -\frac{r^2}{R^2} \sqrt{\frac{g}{2}} \cdot t + c \geq 0, \quad t \geq 0, \quad x > 0.$$

When  $t = 0$  we get from the initial condition that  $c = \sqrt{h_0}$ . Since  $t$  must fulfil

$$-\frac{r^2}{R^2} \sqrt{\frac{g}{2}} \cdot t + \sqrt{h_0} \geq 0,$$

we get

$$0 \leq t \leq \frac{R^2}{r^2} \sqrt{\frac{2h_0}{g}},$$

and thus

$$\sqrt{x} = \sqrt{h_0} - t \cdot \frac{r^2}{R^2} \sqrt{\frac{g}{2}}, \quad t \in \left[0, \frac{R^2}{r^2} \sqrt{\frac{2h_0}{g}}\right].$$

We obtain the solution by squaring

$$\begin{aligned} x &= \left\{ \sqrt{h_0} - t \cdot \frac{r^2}{R^2} \sqrt{\frac{g}{2}} \right\}^2 \\ &= h_0 - t \cdot \frac{r^2}{R^2} \sqrt{2gh_0} + t^2 \cdot \frac{r^4}{R^4} \cdot \frac{g}{2}, \quad t \in \left[0, \frac{R^2}{r^2} \sqrt{\frac{2h_0}{g}}\right]. \end{aligned}$$

C. Let  $x$  be given as above. Then

$$\sqrt{x} = \sqrt{h_0} - t \cdot \frac{r^2}{R^2} \sqrt{\frac{g}{2}}, \quad t \in \left[ 0, \frac{R^2}{r^2} \sqrt{\frac{2h_0}{g}} \right],$$

hence by a differentiation

$$\frac{d(\sqrt{x})}{dt} = \frac{1}{2} \frac{1}{\sqrt{x}} \frac{dx}{dt} = -\frac{r^2}{R^2} \sqrt{\frac{g}{2}},$$

from which

$$\frac{dx}{dt} = -\frac{r^2}{R^2} \sqrt{\frac{g}{2}} \cdot 4x = -\frac{r^2}{R^2} \sqrt{2gx},$$

which is precisely Torricelli's law.

Finally, it is trivial that  $h(0) = h_0$ , and since

$$x > 0 \quad \text{for} \quad t < \frac{R^2}{r^2} \sqrt{\frac{2h_0}{g}},$$

the uniqueness follows from the *Existence and Uniqueness Theorem*.

**Example 6.4** A rope is wound round a tree. The ends of the rope are affected by the two forces  $S_1$  and  $S_2$ . We shall in the following assume that  $S_1$  is a constant and that the rope is at rest and that the slightest increase of  $S_2$  will make the rope slide. The corresponding force  $S_2$  is an increasing function of the angle  $\theta$ , by which the rope is wound round the tree,  $S_2 = S_2(\theta)$ . It can be shown that  $S_2$  is determined by the differential equation

$$\frac{dS_2}{d\theta} = \mu S_2,$$

where  $\mu$  is a constant, which is determined by the pair of materials (rope, tree). We shall assume that  $\mu = 0,2 \text{ rad}^{-1}$ . How much of the rope must be wound round the tree, if  $S_1$  is in equilibrium with a force  $S_2$  which is 100 times as big?

A. We have given a differential equation with an initial condition. One shall find  $\frac{\theta}{2\pi} \geq 0$  (where 1 winding around the tree is put equal to  $2\pi$  rad), such that  $S(\theta) = S_2$ , where  $S_2 = 100 S_1$ .

D. Find the complete solution of the differential equation and then solve the equation

$$S(\theta) = S_2 = 100 S_1$$

with respect to  $\theta$ . The number of windings is then  $\frac{\theta}{2\pi}$ .



I. The solution of

$$\frac{dS}{d\theta} = \mu S, \quad S(0) = S_1,$$

is by inspection

$$S(\theta) = S_1 e^{\mu\theta}.$$

Then we shall solve the equation

$$S_1 e^{\mu\theta} = S_2 = 100 S_1$$

with respect to  $\theta$ , i.e.

$$\theta = \frac{1}{\mu} \ln 100 = 5 \cdot 2 \ln 10 = 10 \ln 10 \text{ rad.}$$

Since 1 winding round the tree corresponds to  $2\pi$  radians, we shall wind the rope

$$\frac{10 \ln 10}{2\pi} \approx 3,7$$

times round the tree.

**Example 6.5** *When one inflates a tyre of an automobile the valve of the tyre is connected with a container which contains compressed air. We shall in the following assume that the pressure in the container is constant during the inflation.*

*The pressure of the tyre  $p$  measured in kPa is described as a function in time  $t$ , measured in seconds. During the inflation, the pressure of the tyre increases in such a way that the velocity by which it increases is proportional to the difference of the pressures of the container and the tyre. Assume that the factor of proportionality is 0.02 (in general this constant depends among other things of the volume of the tyre and of the air resistance in the valve), and that the pressure in the container is 1000 kPa.*

- 1) *Formulate the assumption above concerning the increase of the pressure of the tyre  $p(t)$  by means of  $p'(t)$ , and derive a differential equation for  $p(t)$ .*
- 2) *How long time will it take to inflate a flat tyre, i.e. a tyre in which the pressure is 1 atm. = 101 kPa, until the pressure is 190 kPa?*

A. 1) Set up a model.

2) Solve the found differential equation in a special case.

D. 1) Analyze the text above in order to formulate a differential equation for the pressure of the tyre  $p(t)$ . Since we later shall solve (2) we shall find the complete solution.

2) In the given case one shall set up the initial condition for the differential equation. Solve the initial value problem and find  $t$  for the final condition.

- I. 1) The *change*  $p'(t)$  of the pressure of the tyre is assumed to be *proportional* (with the factor  $0.02 = \frac{1}{50}$ ) with the *difference of the pressures*  $1000 - p(t)$  between the container and the tyre. In other words:

$$p'(t) = 0,02 \cdot \{1000 - p(t)\} = 20 - \frac{1}{50} p(t),$$

which can be written as the linear differential equation of first order with constant coefficients,

$$p'(t) + \frac{1}{50} p(t) = 20.$$

The corresponding homogeneous equation has (by inspection) the complete solution  $c \cdot \exp\left(-\frac{1}{50} t\right)$ , and one guesses the particular solution  $p_0(t) = 1000$ . The complete solution of the model equation is then

$$p(t) = 1000 + c \cdot \exp\left(-\frac{1}{50} t\right), \quad t \geq 0, \quad c \in \mathbb{R}.$$

- 2) For  $t = 0$  we have  $p(0) = 101$ . When this value is put into the complete solution, we can find  $c$  from the equation

$$p(0) = 101 = 1000 + c,$$

Please click the advert

**THE MILKWAY**  
LAUNCHING GRADUATE CAREERS

**MILKROUND SYSTEM**  
Become a business star with internships, placements, graduate jobs & schemes from leading companies.  
[www.milkround.com](http://www.milkround.com)

**PLANET CAREER ADVICE**  
Inhabited by insights into business careers and orbited by application advice.

**FIRST CONTACT**  
Get matched to top business employers via intelligent emails landing in your inbox.

**Milkround.com: rated the #1 graduate recruitment website in the UK Graduate Careers Survey 2009 of 16,000 university finalists.**

**Milkround.com**

thus  $c = -899$ . The wanted solution is then

$$p(t) = 1000 - 899 \exp\left(-\frac{1}{50}t\right), \quad t \geq 0.$$

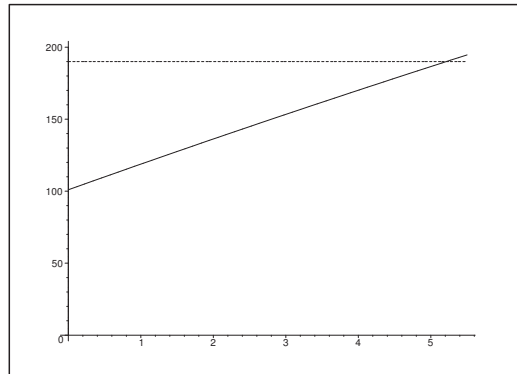

Figure 36: The intersection point of the graph for  $p(t) = 1000 - 899 \exp\left(-\frac{t}{50}\right)$  and the line  $x = 190$ .

The task is to find  $t$  from the equation  $p(t) = 190$ , i.e.

$$1000 - 899 \exp\left(-\frac{1}{50}t\right) = 190.$$

We get by a rearrangement

$$899 \exp\left(-\frac{1}{50}t\right) = 1000 - 190 = 810,$$

i.e.

$$\exp\left(-\frac{1}{50}t\right) = \frac{810}{899},$$

and thus

$$t = 50 \cdot \ln \frac{899}{810} \approx 5,2 \text{ seconds.}$$

**C.** The test of the differential equation has almost been done by the guessing above. Then let

$$p(t) = 1000 - 899 \exp\left(-\frac{1}{50}t\right).$$

For  $t = 0$  we get  $p(0) = 1000 - 899 = 101$ , and we see that the initial condition is also fulfilled.

For  $t = 50 \ln \frac{899}{810}$  we get

$$p\left(50 \ln \frac{899}{810}\right) = 1000 - 899 \exp\left(-\ln \frac{899}{810}\right) = 1000 - 810 = 190,$$

and the final condition is also satisfied.

The remaining parts of the test are left to the reader.

**Example 6.6** Consider an ideal gas in a container of fixed volume  $v_0$ . (For an ideal gas we have that the pressure = volume  $\times$  temperature).

(A) The gas is heated in such a way that the increase of the temperature in a small time interval is proportional to the length of the time interval and to the temperature at the start of the time interval.

- 1) Set up a differential equation for the temperature  $T(t)$  to any time  $t$ . We denote the proportional factor by  $k$  and it will here be considered as known.
- 2) Assume that the pressure of the gas by this heating is doubled in 5 minutes. How many minutes will it take to treble the pressure? (Start by finding  $k$ ).

(B) Then assume that the gas is heated in such a way that the increase of the temperature in a small time interval is proportional to the length of the time interval and to the square of the temperature at the start of the time interval.

3. Assume that the pressure of the gas in this heating to the time  $t = 0$  is  $p = 1$  atm., and to the time  $t = 5$  minutes is  $p = 6$  atm. Assuming the present model, when will the container surely have been blown up, no matter how big  $v_0$  is?

A. Two separate tasks A and B, of which A contains two questions and B one.

- (A) 1) Set up of a mathematical model.  
 2) Use the ideal gas equation to find the time, when the pressure is trebled.
- (B) A latent new setup of a model (one may expect a nonlinear differential equation).  
 3. One should be surprised the first time one reads the claim, until one notices that the equation is nonlinear. We may expect a vertical asymptote for the solution  $p(t)$  for some finite  $t = t_0$ , for which the container certainly has blown up.

D. (A) 1) Analyze the text in order to set up a differential equation for  $T(t)$ .  
 2) Exploit  $p(t) = v_0 \cdot T(t)$  to set up an equation in  $p(t)$ . The constant is found by means of an additional condition. Finally, solve the new equation, this time with respect to  $t$ .

(B) 3. Analyze the text in order to set up a differential equation for  $T(t)$ . Apply the same method as in (2), and check the domain of the solution  $p(t)$ .

I. Let  $p(t) > 0$  denote the pressure and  $T(t) > 0$  the absolute temperature to time  $t$ . By the equation of an ideal gas we get

$$p(t) = v_0 \cdot T(t), \quad v_0 > 0 \text{ constant.}$$

(A) 1) The increase of the temperature  $T(t + \Delta t) - T(t)$  is proportional (factor  $k$ ) to the length of the time interval  $\Delta t > 0$  and to the temperature  $T(t)$  at the start of the time interval, i.e.

$$T(t + \Delta t) - T(t) \approx k \cdot \Delta t \cdot T(t).$$

Dividing by  $\Delta t \neq 0$  followed by the limit  $\Delta t \rightarrow 0+$  we get

$$\lim_{\Delta t \rightarrow 0+} \frac{T(t + \Delta t) - T(t)}{\Delta t} = T'(t) = k \cdot T(t).$$

Therefore, the differential equation becomes

$$T'(t) = k \cdot T(t)$$

with the complete solution

$$T(t) = c \cdot e^{kt}, \quad t \in \mathbb{R}, \quad c > 0.$$

2) Since  $T(t) = \frac{1}{v_0} \cdot p(t)$ , the corresponding differential equation of  $p(t)$  is

$$p'(t) = k \cdot p(t)$$

with the complete solution

$$p(t) = cv_0 \cdot e^{kt}, \quad t \in \mathbb{R}, \quad c > 0.$$

The time is measured in minutes, so the conditions become

$$p(0) = cv_0, \quad p(5) = 2p(0),$$

i.e.

$$cv_0 \cdot e^{5k} = 2cv_0,$$

thus  $e^{5k} = 2$ , and we get  $k = \frac{1}{5} \ln 2$ .

The next task is to use this  $k$  to find  $t$  of the equation

$$p(t) = cv_0 \cdot \exp\left(\frac{1}{5} \ln 2 \cdot t\right) = 3p(0+) = ccv_0.$$

It is immediately seen that  $\exp\left(\frac{1}{5} \ln 2 \cdot t\right) = 3$  has the solution

$$t = 5 \cdot \frac{\ln 3}{\ln 2} \approx 8 \text{ minutes.}$$

**(B)** The setup of the model is done in precisely the same way as in (1). The only difference is that  $T(t)$  on the right hand side is replaced by  $\{T(t)\}^2$ . Therefore, the model equation becomes in this case

$$T'(t) = k \cdot \{T(t)\}^2.$$

**3.** When  $T(t) = \frac{1}{v_0} \cdot p(t)$ , we obtain the corresponding differential equation of  $p(t)$ :

$$p'(t) = \frac{k}{v_0} \{p(t)\}^2, \quad t \in \mathbb{R}, \quad p > 0, \quad k > 0, \quad v_0 > 0.$$

We solve this equation by a separation of the variables. A division by  $-\{p(t)\}^2 \neq 0$  gives

$$-\frac{1}{\{p(t)\}^2} \frac{dp}{dt} = \frac{d}{dt} \left\{ \frac{1}{p(t)} \right\} = -\frac{k}{v_0} = -k_0, \quad k_0 = \frac{k}{v_0},$$

hence by an integration

$$\frac{1}{p(t)} = c - k_0 t, \quad \text{for } c - k_0 t > 0, \text{ dvs. } t < \frac{c}{k_0}.$$

Thus the general solution is

$$p(t) = \frac{1}{c - k_0 t} \quad \text{for } t < \frac{c}{k_0}.$$

Then use the initial condition,

$$p(0) = 1 = \frac{1}{c}, \quad \text{dvs. } c = 1,$$

and the side condition,

$$\frac{1}{p(5)} = \frac{1}{6} = c - 5k_0 = 1 - 5k_0, \quad \text{dvs. } k_0 = \frac{1}{6}.$$

Hence the solution is

$$p(t) = \frac{1}{c - k_0 t} = \frac{6}{6 - t}, \quad \text{for } t \in [0, 6[.$$

Since obviously  $p(t) \rightarrow +\infty$  for  $t \rightarrow 6-$ , we conclude under the assumption that the model is correct that the container has exploded earlier than the time  $t = 6$  minutes.

Please click the advert

**CHALLENGE YOURSELF**

**WWW.STUDYINSWEDEN.SE**

Today's job market values ambitious, innovative, perceptive team players. Swedish universities foster these qualities through a forward-thinking culture where you're close to the latest ideas and global trends.

Whatever your career goals may be, studying in Sweden will give you valuable skills and a competitive advantage for your future. [www.studyinsweden.se](http://www.studyinsweden.se)

**Si.**  
Swedish Institute

Download free books at BookBooN.com

**Example 6.7** Consider a ball shaped lump of ice, which is melting with a velocity which is proportional to the area of the surface of the ball. (The proportional factor is denoted by  $-k$ ,  $k > 0$ , and we assume here that  $k$  is known). We assume that the lump of ice is ball shaped through the whole of the melting process. Let  $V(t)$  denote the volume of the lump of ice at time  $t$ .

- 1) Find the surface area of a ball as a function of its volume  $V$ . (The surface area is  $4\pi r^2$ , and the volume is  $\frac{4}{3}\pi r^3$ , where  $r$  denotes the radius).
- 2) Set up a differential equation for  $V(t)$ .
- 3) Find  $V(t)$ ,  $t \geq 0$ , when the radius  $r = 2$  cm to time  $t = 0$ .

**A.** Setup of a mathematical model, and an application of this model.

**D.** 1) Eliminate  $r$  from the two equations.

2) Set up a mathematical model by analyzing the text.

3) Apply the model in a special case. (NB. Notice that we cannot find the value of  $k$ .)

**I.** 1) Let  $A$  denote the surface area. Then

$$A = 4\pi r^2 \quad \text{and} \quad V = \frac{4}{3}\pi r^3.$$

It follows from the latter equation that

$$r = \sqrt[3]{\frac{3V}{4\pi}},$$

which put into the former equation gives

$$A = 4\pi \sqrt[3]{\left(\frac{3V}{4\pi}\right)^2} = \sqrt[3]{36\pi} \cdot V^{\frac{2}{3}}.$$

- 2) The velocity  $V'(t)$  of the melting is proportional (factor  $k < 0$ ) to the surface area  $A = \sqrt[3]{36\pi} \cdot V^{2/3}$ . Then we conclude that the mathematical model is described by the differential equation

$$V'(t) = k \sqrt[3]{36\pi} \cdot V^{\frac{2}{3}}.$$

Putting  $c = \frac{1}{3}k \sqrt[3]{36\pi}$ , this equation can also be written

$$(20) \quad V'(t) = 3c \cdot V^{\frac{2}{3}}, \quad V > 0.$$

Since the volume decreases by the melting, we have  $V'(t) < 0$ , thus  $c < 0$ .

When  $V > 0$ , a division by  $3V^{\frac{2}{3}}$ , gives that (20) is transformed into

$$\frac{1}{3}V^{-\frac{2}{3}} \frac{dV}{dt} = \frac{d\left(V^{\frac{1}{3}}\right)}{dt} = c.$$

Then by an integration

$$\sqrt[3]{V} = ct + k_1, \quad \text{for } ct + k_1 > 0, \text{ i.e. for } t < -\frac{k_1}{c},$$

because  $c < 0$ . Thus we get the complete solution

$$V(t) = \begin{cases} \{ct + k_1\}^3, & \text{for } t < -\frac{k_1}{c}, \\ 0 & \text{for } t \in \mathbb{R} \end{cases} \quad c < 0,$$

of (20), because  $V = 0$  is trivially a solution.

3) When  $r = 2$  for  $t = 0$ , we get

$$V(0) = \frac{4\pi}{3} \cdot 2^3 = k_1^3, \quad \text{i.e. } k_1 = 2 \sqrt[3]{\frac{4\pi}{3}}.$$

Since  $c = \frac{1}{3} k \sqrt[3]{36\pi}$ , where  $k < 0$  is the melting factor, we get the solution

$$\begin{aligned} V &= \{k_1 + ct\}^3 = \left\{ 2 \sqrt[3]{\frac{4\pi}{3}} - \frac{|k|}{3} \sqrt[3]{36\pi} \cdot t \right\}^3 \\ &= \frac{4\pi}{3} \{2 - |k| \cdot t\}^3, \quad t \in \left[ 0, \frac{2}{|k|} \right]. \end{aligned}$$

REMARK. We miss some information in order to find the proportional factor  $k$ .

**Example 6.8** *It starts to snow on a winter day early in the morning, and the snow continues to fall through the whole day. The snow is falling with a constant intensity, i.e. there falls a constant amount of snow per area unite and per time unit.*

- 1) Describe the thickness  $h(t)$  of the layer of snow as a function of the time  $t$ , assuming that this thickness is 0 at time  $t = t_0$ , when it starts snowing.
- 2) The speed by which a snow plough can remove the snow is inversely proportional to the thickness of the layer of snow. Let  $x(t)$  denote the distance which the snow plough has cleared to time  $t$ . Give the expression of  $x(t)$ . (We assume that the snow plough starts at time  $t_1 > t_0$ ).
- 3) A snow plough starts at 11 AM and has cleared 4 km at 2 PM, further 2 km at 5 PM on the same day. When did it start to snow?

**A.** We shall set up two mathematical models, one for the thickness of the layer of snow (first question), and one for how much a snow plough can clear (second question). Finally we are given three conditions which should enable us to calculate when it started to snow.

- D.**
- 1) Set up a mathematical model for the thickness of the layer of snow.
  - 2) Set up a mathematical model (a differential equation) for how much,  $x(t)$ , the snow plough has cleared.
  - 3) Solve the differential equation in (2), and exploit the additional conditions in order to find the unknown constants which are occurring in the complete solution. Hereby find  $t_0$ .



I. 1) Obviously,

$$h(t) = \mu \cdot (t - t_0), \quad t \geq t_0,$$

where  $\mu > 0$  is a constant.

2) We get immediately that

$$(21) \quad x'(t) = \frac{k_1}{h(t)} = \frac{k}{t - t_0}, \quad t > t_0,$$

where  $k = \frac{k_1}{\mu}$ , i.e. the expected differential equation is reduced to the most simple case, namely that of an integration problem.

3) From (21) we get

$$x(t) = k \cdot \ln(t - t_0) + c, \quad t > t_0.$$

We see that we have three unknown constants,  $k$ ,  $t_0$  and  $c$ . Therefore, we can expect three additional conditions:

$$\begin{array}{ll} 11 \text{ AM} & x(11) = 0 = k \cdot \ln(11 - t_0) + c, & 11 > t_0; \\ 2 \text{ PM}, & x(14) = 4 = k \cdot \ln(14 - t_0) + c, \\ 5 \text{ PM}, & x(17) = 4 + 2 = 6 = k \cdot \ln(17 - t_0) + c. \end{array}$$

Thus we get three nonlinear equations

$$\begin{cases} k \cdot \ln(11 - t_0) + c = 0, \\ k \cdot \ln(14 - t_0) + c = 4, \\ k \cdot \ln(17 - t_0) + c = 6, \end{cases}$$

for the three constants. When the first one is subtracted from the latter two we get

$$k \cdot \ln\left(\frac{14 - t_0}{11 - t_0}\right) = 4, \quad k \cdot \ln\left(\frac{17 - t_0}{11 - t_0}\right) = 6,$$

hence

$$3k \cdot \ln\left(\frac{14 - t_0}{11 - t_0}\right) = 12 = 2k \cdot \ln\left(\frac{17 - t_0}{11 - t_0}\right),$$

and thus

$$\left(\frac{14 - t_0}{11 - t_0}\right)^3 = \left(\frac{17 - t_0}{11 - t_0}\right)^2.$$

When this is multiplied by  $(11 - t_0)^3$  it is transferred into

$$(14 - t_0)^3 = (17 - t_0)^2(11 - t_0).$$

This equation is by a small calculation reduced to

$$t_0^2 - 25t_0 + 145 = 0,$$

the solutions of which are

$$t_0 = \frac{1}{2} \{25 \pm \sqrt{45}\} \approx \begin{cases} 15.85, \\ 9.15. \end{cases}$$

Since it started to snow *before* 11 AM, we have  $t_0 = \frac{1}{2}\{25 - \sqrt{45}\}$ , i.e.  $t_0 \approx 9.15$  which corresponds to the time appr. 9<sup>09</sup>, when it started to snow, and where we have used that 0.15 hour is appr. 9 minutes.

**Example 6.9** The circuit on the figure consists of a resistance  $R$ , a condenser with capacity  $C$  and a voltage generator  $E(t) = \cos 2t$ . The voltage  $V(t)$  over the condenser is governed by the differential equation

$$(22) \quad \frac{dV}{dt} + \frac{1}{RC} V = \frac{1}{C} \cos 2t.$$

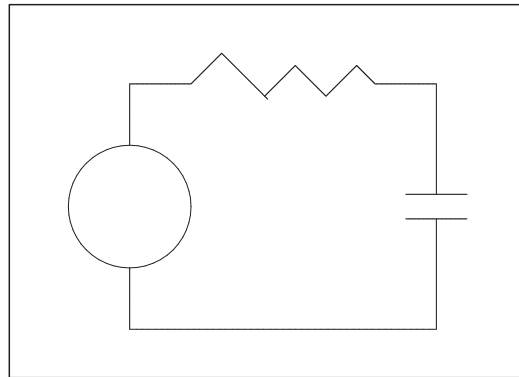

Figure 37: Diagram of an electric circuit with resistance  $R$  and condenser with capacity  $C$  and voltage generator  $E(t) = \cos 2t$ .

1) Determine the constants  $\alpha$  and  $\beta$  such that

$$V(t) = \alpha \cos 2t + \beta \sin 2t$$

is a solution of (22).

2) Find the complete solution of (22).

3) What information should be at hand in order to obtain a given voltage  $V(t)$ ?

**A.** Given a linear differential equation of first order with constant coefficients. Solve the equation, and analyze what kind of information is necessary in order to obtain a unique particular integral.

**D.** 1) Insert the indicated solutions and derive the solution.

2) Find the complete solution (theorem 1.3).

3) Analyze the complete solution concerning initial conditions.

**I.** 1) Inserting  $V = \alpha \cdot \cos 2t + \beta \cdot \sin 2t$ , we get

$$\begin{aligned} \frac{dV}{dt} + \frac{1}{RC} V &= \{-2\alpha \sin 2t + 2\beta \cos 2t\} + \frac{1}{RC} \{\alpha \cos 2t + \beta \sin 2t\} \\ &= \left(2\beta + \frac{\alpha}{RC}\right) \cos 2t + \left(-2\alpha + \frac{\beta}{RC}\right) \sin 2t, \end{aligned}$$

which is equal to  $\frac{1}{C} \cos 2t$  for

$$\frac{1}{RC} \alpha + 2\beta = \frac{1}{C}, \quad \text{and} \quad -2\alpha + \frac{1}{RC} \beta = 0,$$

i.e.

$$\alpha = \frac{R}{1 + \{2RC\}^2}, \quad \beta = \frac{2R^2C}{1 + \{2RC\}^2}.$$

The particular solution is therefore

$$V(t) = \frac{R}{1 + \{2RC\}^2} \cos 2t + \frac{2R^2C}{1 + \{2RC\}^2} \sin 2t.$$

2) The corresponding homogeneous equation has trivially the solution

$$k \cdot \exp\left(-\frac{t}{RC}\right), \quad k \in \mathbb{R}, \quad t \in \mathbb{R}.$$

By theorem 1.3 the complete solution is

$$(23) \quad V(t) = \frac{R}{1 + \{2RC\}^2} \{\cos 2t + 2RC \sin 2t\} + k \cdot \exp\left(-\frac{t}{RC}\right),$$

where  $k \in \mathbb{R}$  is an arbitrary constant, and  $t \in \mathbb{R}$ .

Please click the advert



## DIVERSE - INNOVATIVE - INTERNATIONAL

**Are you considering a European business degree?**

Copenhagen Business School is one of the largest business schools in Northern Europe with more than 15,000 students from Europe, North America, Australia and Asia.

Are you curious to know how a modern European business school competes with a diverse, innovative and international study environment?

Please visit Copenhagen Business School at [www.cbs.dk](http://www.cbs.dk)



**Copenhagen Business School**  
HANDELSHØJSKOLEN

Diversity creating knowledge





Download free books at [BookBooN.com](http://BookBooN.com)

- 3) In order to solve specific problems we must know either  $R$  and  $C$ , or  $R$  and  $RC$ . We still have to consider the constant  $k \in \mathbb{R}$ . Since  $\exp\left(-\frac{t}{RC}\right) \neq 0$  for every  $t \in \mathbb{R}$ , this constant is uniquely determined by (23), if only  $V(t_0) = V_0$  is given for some  $t = t_0$ . In that case

$$k = V_0 \exp\left(\frac{t_0}{RC}\right) - \frac{R \exp(t_0/(RC))}{1 + \{2RC\}^2} \{\cos 2t_0 + 2RC \sin 2t_0\},$$

which is then inserted into (23).

**Example 6.10** Consider a particle of mass  $m$ , which is moving in a straight motion. The position of the particle to time  $t$  is denoted by  $x(t)$  where we measure the distance from a fixed initial point  $0$ . During the motion the particle is only subjected to one force  $f(x)$ , which only depends on the position  $x$ . We assume that  $f(x)$  is continuous and that  $f(x) \neq 0$  for every  $x$ .

According to Newton's second law we get for the velocity  $v(t) = x'(t)$  that

$$m \frac{dv}{dt} = f(x),$$

hence

$$(24) \quad mv \frac{dv}{dt} = f(x) \cdot x'(t).$$

1. Show that if  $V(x)$  is an integral of  $f(x)$ , then we get by an integration of (24) with respect to  $t$  that

$$\frac{1}{2} mv^2 - V(x) = \text{konstant}.$$

We shall only consider that situation, in which a bullet of mass  $m$  is shot into the space in a direction vertically on the surface of the earth. The initial velocity is  $v_0$ , and we assume that the bullet is only influenced by the gravity  $f(x) = -\frac{k}{x^2}$ , where  $k$  is some positive constant. Here  $x$  denotes the distance to the centre of the earth. When the radius of the earth is denoted by  $R$ , we get  $v(R) = v_0$ .

2. Find the velocity of the bullet  $v$  as a function of the distance  $x$ .
3. Find the smallest initial velocity  $v_0$ , for which the bullet can go to infinity from the earth.
4. When the initial speed is less than the  $v_0$  found in (3), how far in the space will the bullet particle go?

**A.** The first question is purely theoretical. The following three problems refer to a given situation. We can assume the given mathematical model of Newton's second law.

- D.**
- 1) Integrate (24).
  - 2) Set up the equation in the special case of an initial condition and solve the equation.
  - 3) Find the smallest  $v_0$ , for which the solution goes to infinity.
  - 4) Find the domain and range, when  $v$  is smaller than the velocity of evasion.

I. 1) Let  $\frac{dV}{dx} = f(x)$ . From

$$0 = mv \frac{dv}{dx} - f(x) = \frac{1}{2} m \frac{d(v^2)}{dx} - \frac{dV}{dx} = \frac{d}{dx} \left\{ \frac{1}{2} mv^2 - V(x) \right\}$$

it follows by an integration that

$$\frac{1}{2} mv^2 - V(x) = c.$$

2) When  $f(x) = -\frac{k}{x^2}$ , then  $V(x) = \frac{k}{x}$ , hence according to (1),

$$\frac{1}{2} mv^2 - \frac{k}{x} = \text{constant}.$$

When  $x = R$ , then  $v(R) = v_0$ , thus the constant is  $\frac{1}{2} mv_0^2 - \frac{k}{R}$ , and we get by insertion,

$$\frac{1}{2} mv^2 = \frac{1}{2} mv_0^2 - \frac{k}{R} + \frac{k}{x} \quad (> 0), \quad x \geq R,$$

and thus

$$v^2 = v_0^2 - \frac{2k}{mR} + \frac{2k}{m} \cdot \frac{1}{x} \quad (> 0), \quad x \geq R.$$

Since  $v > 0$ , we get

$$v(x) = \left\{ v_0^2 - \frac{2k}{mR} + \frac{2k}{m} \cdot \frac{1}{x} \right\}^{\frac{1}{2}}, \quad x \in I_{v_0},$$

where the interval  $I_{v_0}$  has  $R$  as its left boundary point and satisfies

$$v_0^2 - \frac{2k}{mR} + \frac{2k}{m} \cdot \frac{1}{x} > 0 \quad \text{for } x \in I_{v_0},$$

i.e.

$$(25) \quad \frac{1}{x} > \frac{m}{2k} \left\{ \frac{2k}{mR} - v_0^2 \right\} = \frac{1}{R} - \frac{m}{2k} \cdot v_0^2.$$

We note that  $v > 0$ , when  $x$  satisfies this condition.

3) When we can use every  $x \geq R$  in (25), we must have

$$\frac{1}{R} - \frac{m}{2k} v_0^2 \leq 0,$$

i.e.

$$v_0^2 \geq \frac{2k}{mR}, \quad \text{or} \quad v_0 \geq \sqrt{\frac{2k}{mR}}.$$

The smallest velocity (the velocity of evasion) is therefore

$$v_0 = \sqrt{\frac{2k}{mR}}.$$

4) Let  $0 < v_0 < \sqrt{\frac{2k}{mR}}$ . Then the largest height  $x$  is found by writing equality in (25), thus

$$\frac{1}{x} = \frac{1}{R} - \frac{m}{2k} v_0^2 > 0,$$

from which

$$x = \frac{1}{\frac{1}{R} - \frac{mv_0^2}{2k}} = \frac{2kR}{2k - mRv_0^2}.$$

**Example 6.11** *The following example is the first one of two examples in which we show that the possible motions of a planet can be found from two basic laws. We consider a particle  $P$ , which is moving in a plane, in which we have given an  $(x, y)$  coordinate system. To any time  $t$  the position of the particle is given by its coordinates  $x(t)$  and  $y(t)$ .*

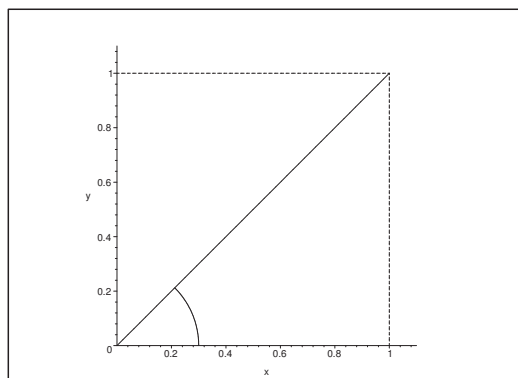

Figure 38: Radius vector  $r(t)$  and the angle  $\theta(t)$  for the particle  $P$ , and the orthogonal projections  $x(t)$  and  $y(t)$  onto the axes

We can also in another way determine the coordinates, namely by determining the two variables  $r(t)$  and  $\theta(t)$  given on the figure (polar coordinates). Here  $r(t)$  indicates the usual distance from  $0$  to  $P$ , and  $\theta(t)$  is the angle from the  $x$  axis to the line  $OP$  chosen in such a way that  $\theta(t)$  becomes continuous. We assume that  $x(t)$ ,  $y(t)$ ,  $r(t)$  and  $\theta(t)$  are twice differentiable functions. In the following we shall often neglect  $t$  and just write  $x$ ,  $y$ ,  $r$ ,  $\theta$ .

Let us assume that the sun is situated at  $0$  and that the planet  $P$  during its motion is only influenced by the mass attraction of the sun  $\mathbf{F}(t)$ . Since  $\mathbf{a}_1 = (\cos \theta, \sin \theta)$ ,  $\mathbf{a}_2 = (-\sin \theta, \cos \theta)$ , we see that  $\mathbf{F}(t)$  is determined by

$$\mathbf{F}(t) = -\frac{k}{r^2(t)} \mathbf{a}_1(t),$$

where  $k$  is a constant. Then by Newton's second law we get

$$\mathbf{F}(t) = m \cdot (x''(t), y''(t)),$$

where  $m$  denotes the mass of the planet.

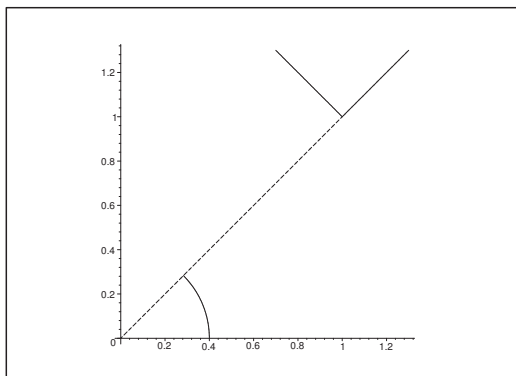

Figure 39: The sun is situated at 0, and the planet at P. The outer normal is  $\mathbf{a}_1 = (\cos \theta, \sin \theta)$ , and the perpendicular vector is  $\mathbf{a}_2 = (-\sin \theta, \cos \theta)$ .

1) It follows from the first figure that

$$x(t) = r(t) \cos \theta(t), \quad y(t) = r(t) \sin \theta(t).$$

Find by a differentiation with respect to  $t$  the accelerations  $x''(t)$  and  $y''(t)$  expressed by  $r(t)$  and  $\theta(t)$  and the derivatives of first and second order of these functions.

2) Let  $\mathbf{a}(t) = (x''(t), y''(t))$ . Prove from (1) that

$$\mathbf{a}(t) = \{r''(t) - r(t)(\theta'(t))^2\} \mathbf{a}_1 + \{2r'(t) \cdot \theta'(t) + r(t) \cdot \theta''(t)\} \mathbf{a}_2.$$

3) Find the projection of  $\mathbf{a}(t)$  onto the vector  $\mathbf{a}_1$ , and onto the vector  $\mathbf{a}_2$ . Find the projections of  $\mathbf{F}(t)$  på  $\mathbf{a}_1$  and  $\mathbf{a}_2$ .

4) Show that the following two differential equations are fulfilled for every motion of a planet

$$\frac{d^2r}{dt^2} - r \left\{ \frac{d\theta}{dt} \right\}^2 = -\frac{k}{mr^2}, \quad 2 \frac{d\theta}{dt} \cdot \frac{dr}{dt} + r \cdot \frac{d^2\theta}{dt^2} = 0.$$

**A.** Two body problem. Express the law for planet motion in a plane by a mathematical model in polar coordinates. We shall not solve the equations. A procedure is sketched.

**D.** 1) Transfer from rectangular to polar coordinates.

2) Splitting of  $\mathbf{a}(t) = (x''(t), y''(t))$  according to a “moving coordinate system”.

3) Determination of the Projections.

4) The mathematical model.

**I.** 1) Let

$$x(t) = r(t) \cos \theta(t), \quad y(t) = r(t) \sin \theta(t).$$

Then

$$x'(t) = \frac{dr}{dt} \cos \theta - r \sin \theta \cdot \frac{d\theta}{dt},$$

$$x''(t) = \frac{d^2r}{dt^2} \cdot \cos \theta - 2 \frac{dr}{dt} \cdot \frac{d\theta}{dt} \cdot \sin \theta$$

$$- r \cos \theta \cdot \left( \frac{d\theta}{dt} \right)^2 - r \sin \theta \cdot \frac{d^2\theta}{dt^2},$$

and

$$y'(t) = \frac{dr}{dt} \cdot \sin \theta + r \cos \theta \cdot \frac{d\theta}{dt},$$

$$y''(t) = \frac{d^2r}{dt^2} \sin \theta + 2 \frac{dr}{dt} \cdot \frac{d\theta}{dt} \cos \theta$$

$$- r \sin \theta \cdot \left( \frac{d\theta}{dt} \right)^2 + r \cos \theta \cdot \frac{d^2\theta}{dt^2}.$$

Please click the advert



## Sharp Minds - Bright Ideas!

Employees at FOSS Analytical A/S are living proof of the company value - First - using new inventions to make dedicated solutions for our customers. With sharp minds and cross functional teamwork, we constantly strive to develop new unique products - Would you like to join our team?

FOSS works diligently with innovation and development as basis for its growth. It is reflected in the fact that more than 200 of the 1200 employees in FOSS work with Research & Development in Scandinavia and USA. Engineers at FOSS work in production, development and marketing, within a wide range of different fields, i.e. Chemistry, Electronics, Mechanics, Software, Optics, Microbiology, Chemometrics.

**We offer**  
*A challenging job in an international and innovative company that is leading in its field. You will get the opportunity to work with the most advanced technology together with highly skilled colleagues.*

*Read more about FOSS at [www.foss.dk](http://www.foss.dk) - or go directly to our student site [www.foss.dk/sharpminds](http://www.foss.dk/sharpminds) where you can learn more about your possibilities of working together with us on projects, your thesis etc.*

The Family owned FOSS group is the world leader as supplier of dedicated, high-tech analytical solutions which measure and control the quality and production of agricultural, food, pharmaceutical and chemical products. Main activities are initiated from Denmark, Sweden and USA with headquarters domiciled in Hillerød, DK. The products are marketed globally by 23 sales companies and an extensive net of distributors. In line with the corevalue to be 'First', the company intends to expand its market position.







Dedicated Analytical Solutions

FOSS  
 Slangerupgade 69  
 3400 Hillerød  
 Tel. +45 70103370  
[www.foss.dk](http://www.foss.dk)



2) If we put  $\mathbf{a}_1 = (\cos \theta, \sin \theta)$  and  $\mathbf{a}_2 = (-\sin \theta, \cos \theta)$ , we get by a small calculation that

$$\begin{aligned} \mathbf{a}(t) &= (x''(t), y''(t)) \\ &= \left( \left\{ \frac{d^2 r}{dt^2} - r \left( \frac{d\theta}{dt} \right)^2 \right\} \cos \theta + \left\{ 2 \frac{dr}{dt} \frac{d\theta}{dt} + r \frac{d^2 \theta}{dt^2} \right\} (-\sin \theta), \right. \\ &\quad \left. \left\{ \frac{d^2 r}{dt^2} - r \left( \frac{d\theta}{dt} \right)^2 \right\} \sin \theta + \left\{ 2 \frac{dr}{dt} \frac{d\theta}{dt} + r \frac{d^2 \theta}{dt^2} \right\} \cos \theta \right) \\ &= \left\{ \frac{d^2 r}{dt^2} - r \left( \frac{d\theta}{dt} \right)^2 \right\} (\cos \theta, \sin \theta) \\ &\quad + \left\{ 2 \frac{dr}{dt} \cdot \frac{d\theta}{dt} + r \frac{d^2 \theta}{dt^2} \right\} (-\sin \theta, \cos \theta) \\ &= \{r''(t) - r(t)[\theta'(t)]^2\} \mathbf{a}_1 + \{2r'(t)\theta'(t) + r(t)\theta''(t)\} \mathbf{a}_2. \end{aligned}$$

3) Since  $\mathbf{a}_1$  and  $\mathbf{a}_2$  are perpendicular unit vectors, the projections are simply the coefficients of  $\mathbf{a}_1$  and  $\mathbf{a}_2$  respectively:

$$\begin{aligned} \text{Projection onto } \mathbf{a}_1 : & \quad \frac{d^2 r}{dt^2} - r \left( \frac{d\theta}{dt} \right)^2, \\ \text{Projection onto } \mathbf{a}_2 : & \quad 2 \frac{dr}{dt} \cdot \frac{d\theta}{dt} + r \cdot \frac{d^2 \theta}{dt^2}. \end{aligned}$$

The corresponding projections of  $\mathbf{F}(t)$  are

$$\begin{aligned} \text{Projection onto } \mathbf{a}_1 : & \quad m \left\{ \frac{d^2 r}{dt^2} - r \left( \frac{d\theta}{dt} \right)^2 \right\}, \\ \text{Projection onto } \mathbf{a}_2 : & \quad m \left\{ 2 \frac{dr}{dt} \cdot \frac{d\theta}{dt} + r \frac{d^2 \theta}{dt^2} \right\}. \end{aligned}$$

If we instead use the expression  $\mathbf{F}(t) = -\frac{k}{r^2(t)} \mathbf{a}_1(t)$  for  $\mathbf{F}(t)$ , we get the projections

$$\begin{aligned} \text{Projection onto } \mathbf{a}_1 : & \quad -\frac{k}{r^2}, \\ \text{Projection onto } \mathbf{a}_2 : & \quad 0. \end{aligned}$$

4) The two different expressions in (3) for the projections if  $\mathbf{F}(t)$  must necessary be equal. Thus we have:

$$\begin{aligned} \frac{d^2 r}{dt^2} - r \left( \frac{d\theta}{dt} \right)^2 &= -\frac{k}{mr^2}, & (\text{projection onto } \mathbf{a}_1), \\ 2 \frac{dr}{dt} \cdot \frac{d\theta}{dt} + r \frac{d^2 \theta}{dt^2} &= 0, & (\text{projektion onto } \mathbf{a}_2). \end{aligned}$$

REMARK. Note that when the latter equation is multiplied by  $r > 0$ , we get

$$\begin{aligned} 0 &= 2r \frac{dr}{dt} \cdot \frac{d\theta}{dt} + r^2 \frac{d^2 \theta}{dt^2} \\ &= \frac{d}{dt} (r^2) \cdot \frac{d\theta}{dt} + r^2 \frac{d}{dt} \left( \frac{d\theta}{dt} \right) = \frac{d}{dt} \left\{ r^2 \frac{d\theta}{dt} \right\}, \end{aligned}$$

whence by an integration

$$r^2 \frac{d\theta}{dt} = c.$$

When  $c \neq 0$ , then  $\frac{\theta}{dt} \neq 0$ , and  $\theta(t)$  has an inverse function  $t(\theta)$ . It is seen by composition that  $r = r(t(\theta))$  can be considered as a function in  $\theta$ . Then we get by an integration

$$\int r^2(\theta) d\theta = \int c dt = ct + k.$$

The integral  $\int r^2(\theta) d\theta$  can be interpreted as the area of the domain which the radius vector  $r(\theta)$  sweeps over. If  $k = 0$  from the beginning, then this area is proportional to the time  $t$ .

**Example 6.12** *This example is a continuation of Example 6.11. When we put  $\omega = \frac{d\theta}{dt}$ , we get the following two differential equations for the motion*

$$(26) \quad \frac{d^2r}{dt^2} - r\omega^2 = -\frac{k}{mr^2},$$

$$(27) \quad 2\omega \frac{dr}{dt} + r \frac{d\omega}{dt} = 0.$$

1) Prove from (27) that there is a constant  $c$ , such that we during the motion have

$$r^2(t)\omega(t) = c.$$

2) What kind of motion do we get when  $c = 0$ ?

3) We then assume that  $c \neq 0$ . Prove that  $\theta(t)$  has an inverse function  $t = g(\theta)$ . Prove also that if we introduce the function  $u$  by

$$u(t) = \frac{1}{r(t)},$$

then

$$\frac{dr}{dt} = -c \frac{du}{d\theta}, \quad \frac{d^2r}{dt^2} = -c^2 u^2 \frac{d^2u}{d\theta^2}.$$

4) The point is now that one from (26) can find a fairly simple differential equation for  $u$  as a function in  $\theta$ . Hint: Show that

$$\frac{d^2u}{d\theta^2} + u = K$$

for some constant  $K$ .

**A.** Continuation of Example 6.11, with very strong guidelines.

**D.** 1) Multiply (27) by  $r > 0$  and integrate.

- 2) Consider the case  $c = 0$ .
- 3) Show that when  $c \neq 0$ , then  $t(\theta)$  is defined, and express  $\frac{dr}{dt}$  and  $\frac{d^2r}{dt^2}$  by a differentiation with respect to  $\theta$ .
- 4) Derive a differential equation of second order with constant coefficients  $r$ .
- I. 1) We must for physical reasons have  $r > 0$ , so when (27) is multiplied by  $x$ , we obtain the equivalent equation

$$0 = \omega \cdot 2r \frac{dr}{dt} + r^2 \frac{d\omega}{dt} = \omega \frac{d}{dt} (r^2) + r^2 \frac{d\omega}{dt} = \frac{d}{dt} (r^2\omega),$$

hence by an integration

$$r(t)^2\omega(t) = c.$$

- 2) When  $c = 0$ , then  $\omega = \frac{d\theta}{dt} = 0$ , because  $r > 0$ . This means that  $\theta = k$ . Then the motion is radial, i.e. it is bound to a half line from the centre.
- 3) When  $c \neq 0$ , then  $\omega(t) = \frac{d\theta}{dt} = \frac{c}{r(t)^2} \neq 0$ , and  $\frac{d\theta}{dt}$  has the same sign as  $c$ . Consequently the inverse function of  $\theta(t)$  exists,  $t = g(\theta)$ .

Please click the advert







[www.1calendar.dk](http://www.1calendar.dk)

If we put  $u(t) = \frac{1}{r(t)}$ , i.e.  $r(t) = \frac{1}{u(t)}$ , then  $\omega = \frac{c}{r^2} = cu^2$ , and

$$\begin{aligned}\frac{dr}{dt} &= \frac{d}{d\theta} \left( \frac{1}{u} \right) \cdot \frac{d\theta}{dt} = -\frac{1}{u^2} \frac{du}{d\theta} \cdot \omega \\ &= -\frac{1}{u^2} \cdot cu^2 \frac{du}{d\theta} = -c \frac{du}{d\theta}.\end{aligned}$$

Furthermore,

$$\begin{aligned}\frac{d^2r}{dt^2} &= \frac{d}{dt} \left( \frac{dr}{dt} \right) = \frac{d}{d\theta} \left( -c \frac{du}{d\theta} \right) \cdot \frac{d\theta}{dt} \\ &= -c \frac{d^2u}{d\theta^2} \cdot \omega = -c^2 u^2 \frac{d^2u}{d\theta^2}.\end{aligned}$$

4) Finally, we get by insertion into (26) that

$$\begin{aligned}0 &= \frac{d^2r}{dt^2} - r\omega^2 + \frac{k}{mr^2} \\ &= -c^2 u^2 \frac{d^2u}{d\theta^2} - \frac{1}{u} \cdot c^2 u^4 + \frac{ku^2}{m} \\ &= -c^2 u^2 \left\{ \frac{d^2u}{d\theta^2} + u - \frac{k}{c^2 m} \right\}.\end{aligned}$$

Since  $c^2 u^2 \neq 0$ , we can rewrite this equation in the form

$$\frac{d^2u}{d\theta^2} + u = \frac{k}{c^2 m} = K.$$

## 7 MAPLE programmes

**Example 7.1** Write a MAPLE programme, which sketches the graph of one of the solutions of the differential equation

$$\frac{dx}{dt} + 2tx = t^2, \quad t \in [-2, 2].$$

- A. MAPLE programme for a solution of a linear and inhomogeneous differential equation of first order.
- D. First set up the solution formula: Notice that the integral is of a type which cannot be expressed by elementary functions. The MAPLE programme is of course not unique. I shall below indicate the commands which were used by the figure.

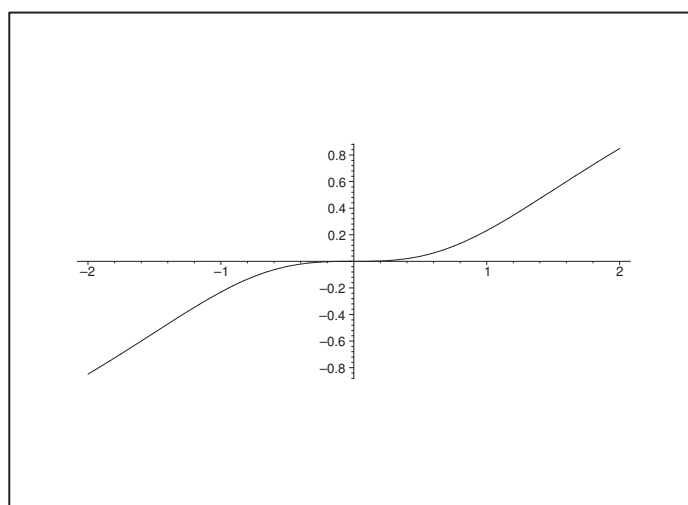

Figure 40: The graph of  $x_0(t) = \frac{1}{2}t - \frac{1}{2}e^{-t^2} \int_0^t e^{\tau^2} d\tau$ .

- I. The complete solution is given by a formula, which we shall reduce as much as possible,

$$\begin{aligned} x(t) &= e^{-t^2} \int_0^t e^{\tau^2} \cdot \tau^2 d\tau + c \cdot e^{-t^2} \\ &= e^{-t^2} \left\{ \frac{1}{2} t e^{t^2} - \frac{1}{2} \int e^{t^2} dt + c \right\} \\ &= \frac{1}{2} t - \frac{1}{2} e^{-t^2} \int_0^t e^{\tau^2} d\tau + c \cdot e^{-t^2}. \end{aligned}$$

REMARK 1. We thus perform a partial integration in order to get a simpler integrand. Even if the MAPLE programme should be able directly to calculate the first integral, it of course allowed also to make the calculations easier for MAPLE, hence increase the speed of the calculations.  $\diamond$

We only want to sketch the graph of one solution, so we choose  $c = 0$ , in which case we get the solution

$$x_0(t) = \frac{1}{2}t - \frac{1}{2}e^{-t^2} \int_0^t e^{x^2} dx.$$

A MAPLE programme for drawing this graph in the interval  $[-2, 2]$  is e.g. given by

```
plot([t,t/2-exp(-t^2)/2*int(exp(x^2),x=0..t),t=-2..2],
      scaling=constrained,color=black);
```

There are of course other possibilities.

Remark 2. In cases like this where one cannot find the exact expression of the solution by elementary functions, we can see that MAPLE is really of great help. However, in other cases it is actually easier *not* to use MAPLE, which should only be considered as an useful tool.  $\diamond$

Please click the advert

**Design your  
own future at  
MAN Diesel**

[www.mandiesel.com](http://www.mandiesel.com)

**MAN Diesel – Powering the World**



Download free books at [BookBooN.com](http://BookBooN.com)